

- ① Use No. 6 @ 6" longitudinal and No. 5 @ 1' 0" transverse reinforcement
- ② See Joint Detail

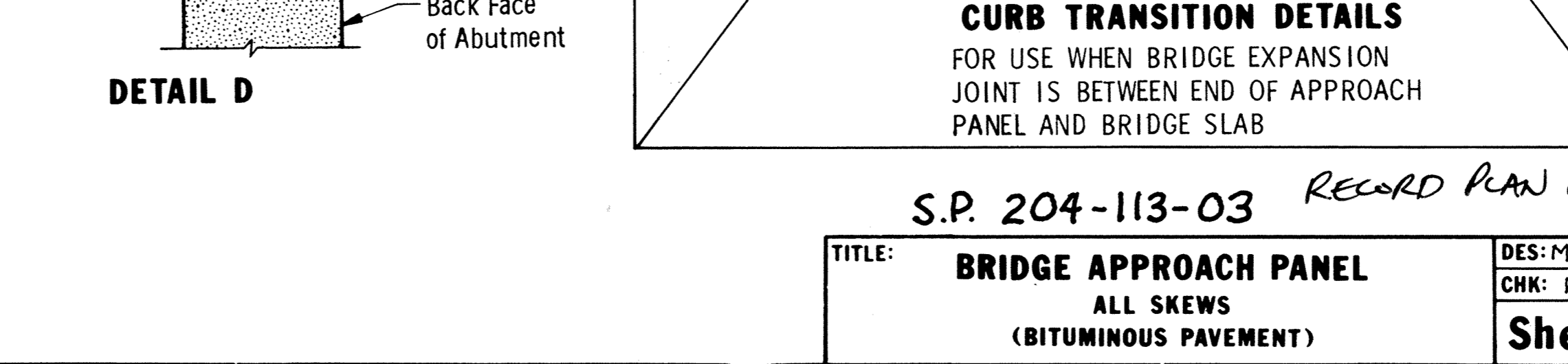
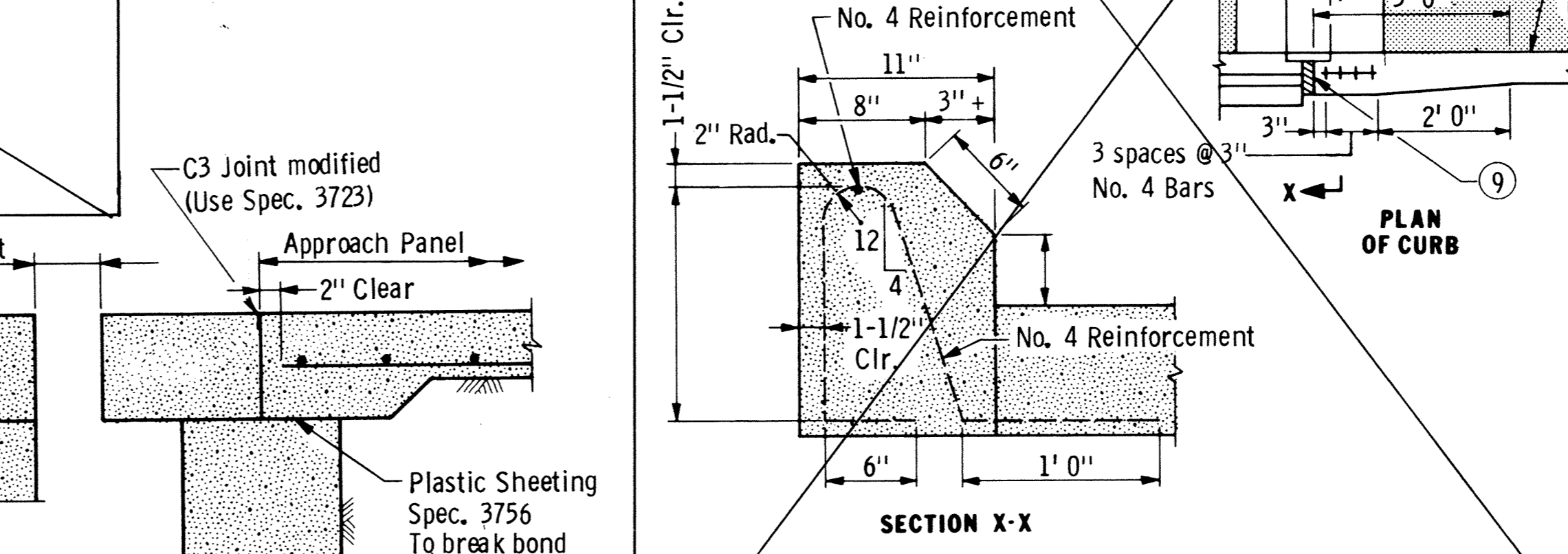
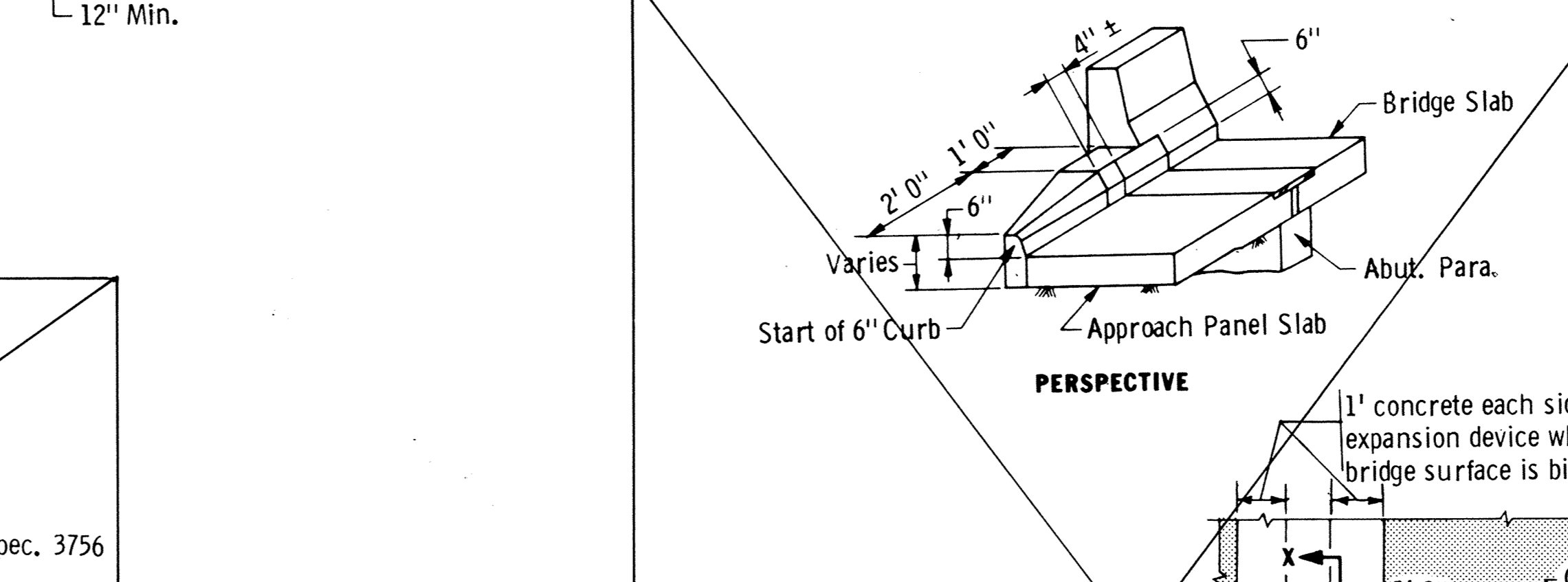
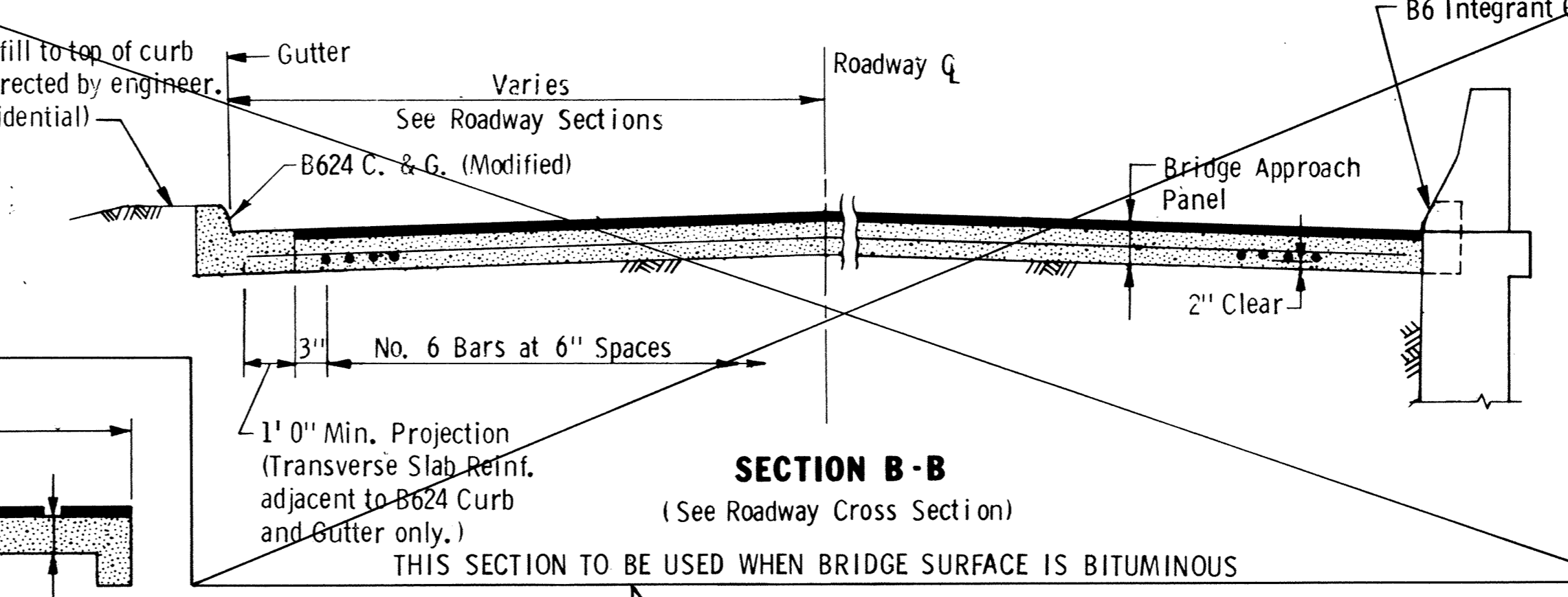
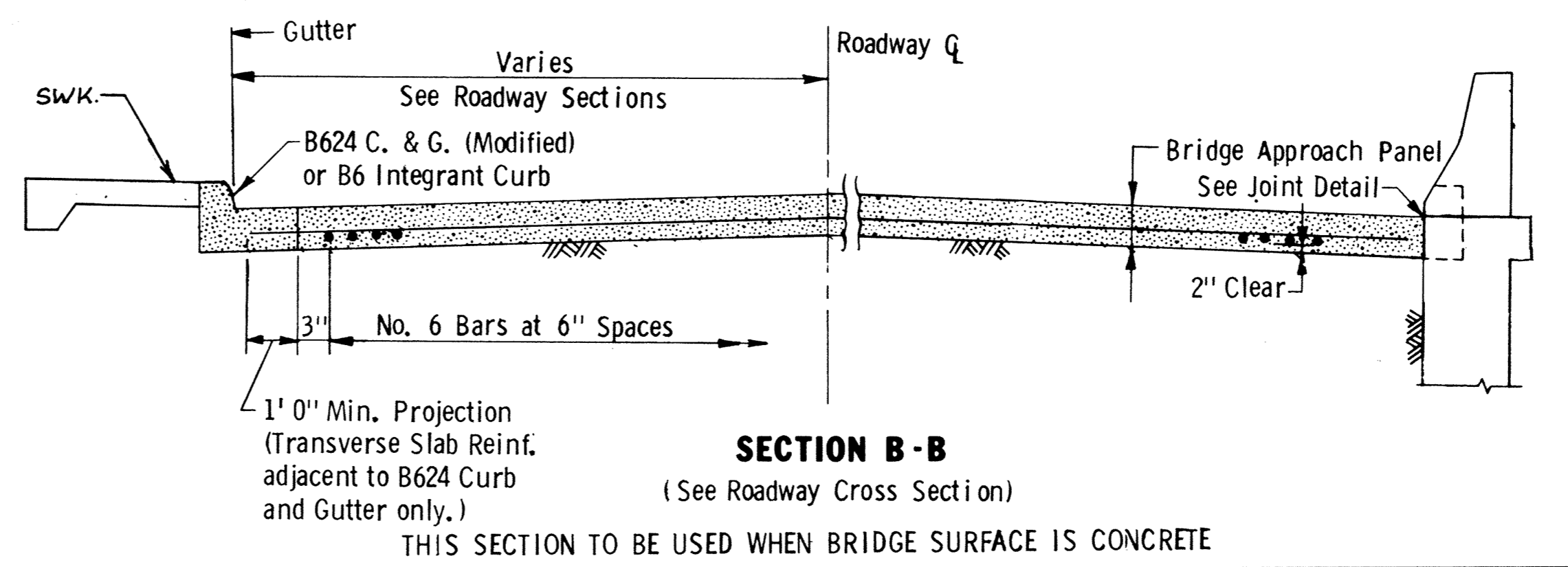
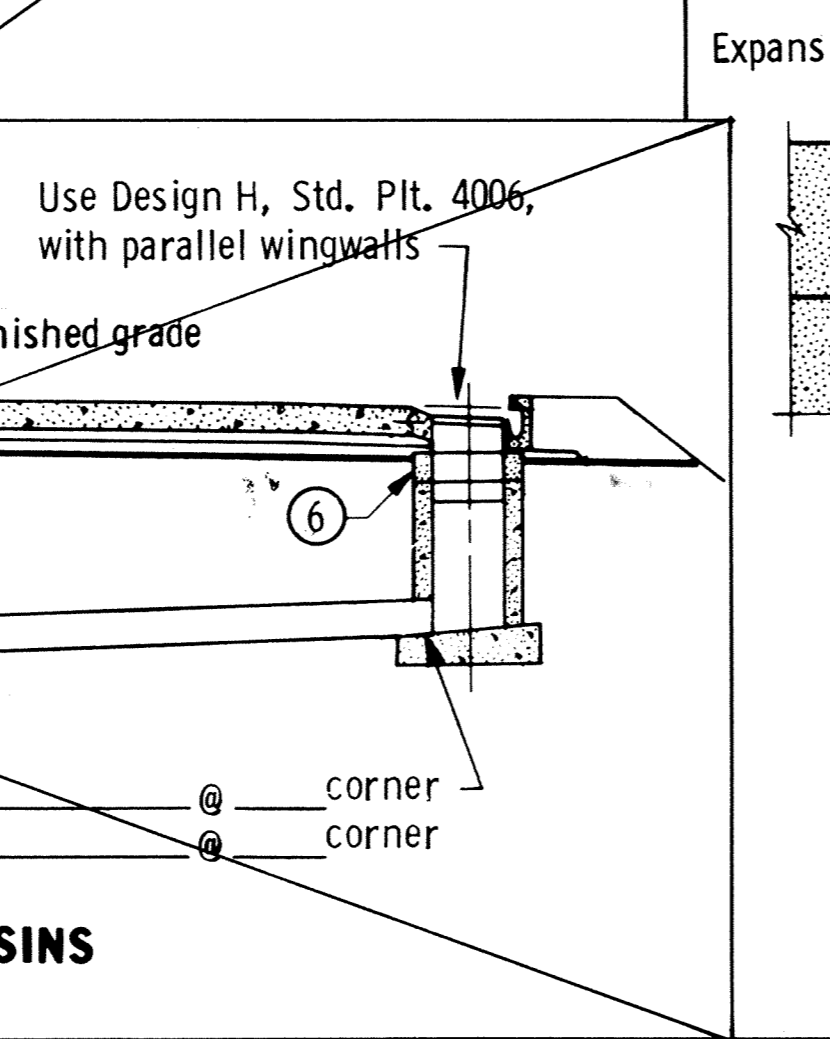
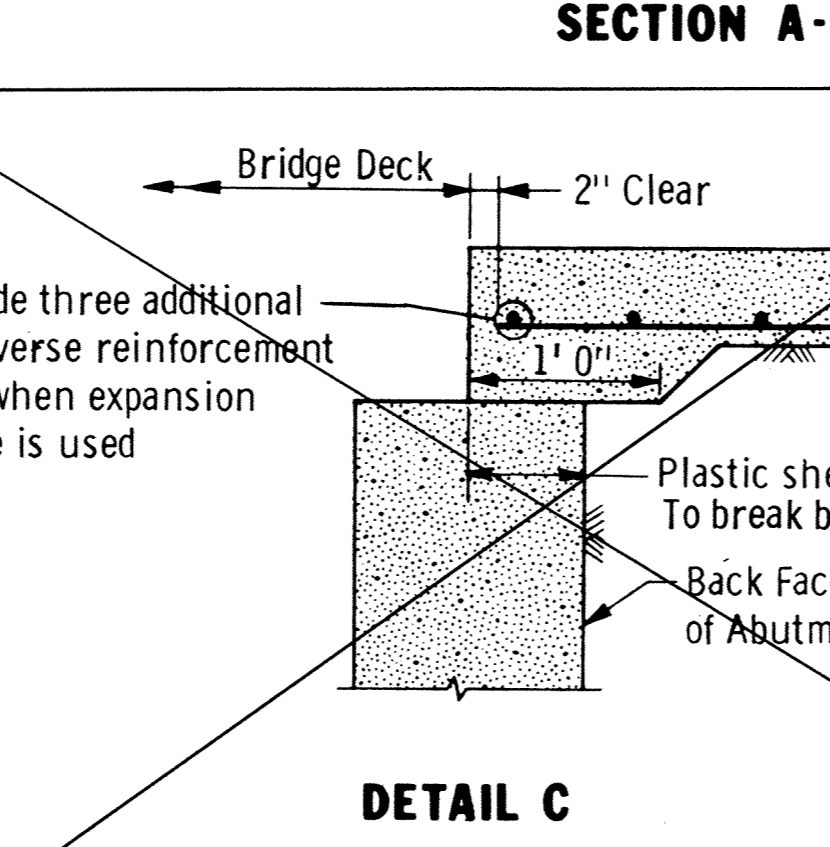
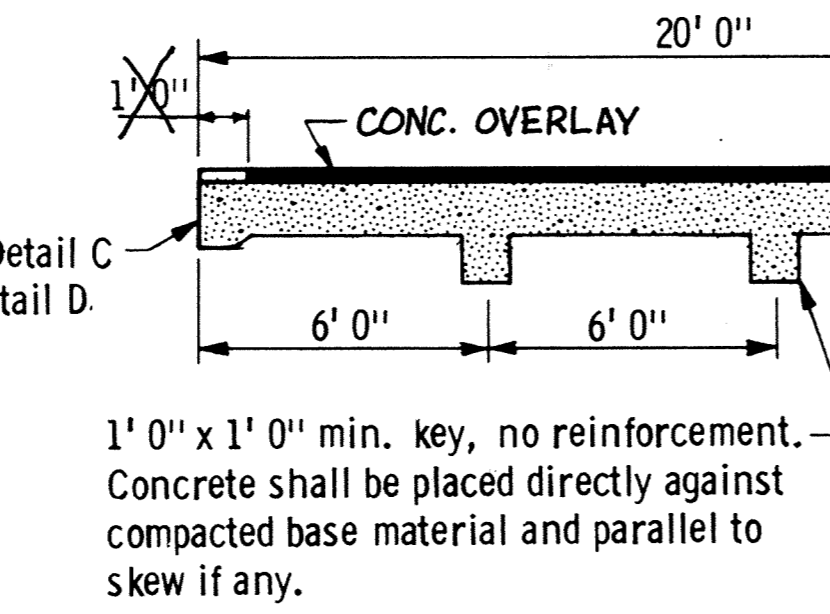
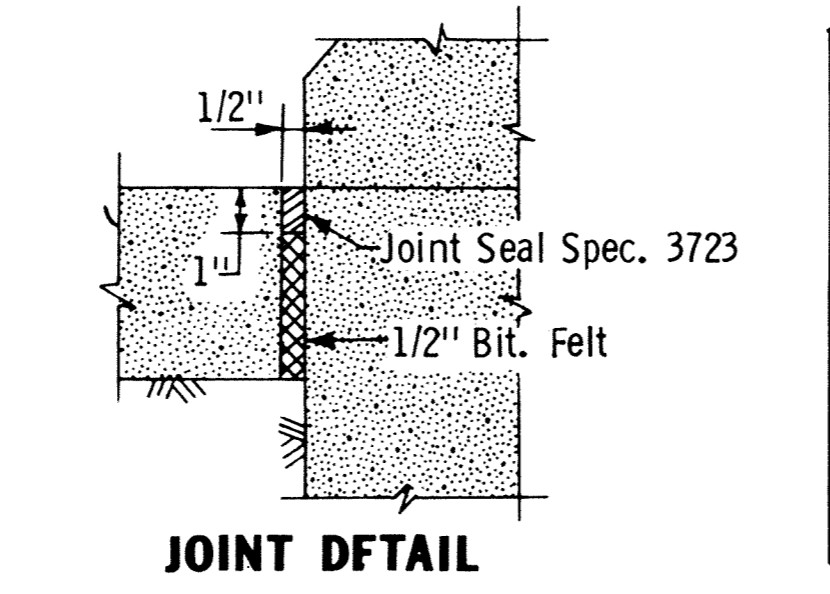

The summary of quantities for approach panel is as shown below. Any additional minor items and slight changes of quantities required shall be furnished by the contractor with no additional compensation, except as noted.

ITEM	*MANUAL REFERENCE
Sodding at Pipe Culverts	Std. Plts. 9102
Riprap at CMP Outlets	Std. Plts. 3134
Metal Apron for CM Pipe	Std. Plts. 3123
Curb and Gutter	Std. Plt. 7100
Catch Basin Details	Std. Plt. 4002
Catch Basin Details	Std. Plt. 4006
Precast Concrete Base	Std. Plt. 4011
Catch Basin Frame	Std. Plt. 4129
Catch Basin Curb Box	Std. Plt. 4160
Catch Basin Grate	Std. Plt. 4151
Catch Basin Installation	Std. Plt. 7111
Metal Pipe Flume	Std. Plt. 5000
Longitudinal Joints	Std. Plt. 1140
Integrant Curbs	Std. Plt. 7000
Contraction Joint	Std. Plt. 1120
Conc. Short Cone & Adj. Ring	Std. Plt. 4010

\*Specification Ref. Std. Plts. 0001 & 0002  
Reinforcement shall be lapped as per Spec. 2472.3D

③ SUMMARY OF QUANTITIES FOR BRIDGE APPROACH PANELS

④ Concrete Mix No. 3X42	66	Cu. Yd.
⑤ Catch Basins		Req'd.
⑥ Metal Apron		Req'd.
⑦ Reinforcement Bars, EPOXY-COATED 6980		Lbs.
⑧ 12" C.M. Pipe Drain		Lin. Ft.
⑨ Curb, Design B6	12	Lin. Ft.
12" R.C. Pipe Drain		Lin. Ft.
CONC. OVERLAY TYPE SPECIAL	1760	Sq. Ft.
Sod		Sq. Yd.
Random Riprap Class "A"		Cu. Yd.

- ③ Quantities listed are for approach panels at both ends of bridge
- ④ Payment will be included in the single lump sum price for "Item 301.601 Bridge Approach Panels."
- ⑤ The Volume of concrete shown is based on an average slab depth of 12" plus the volume of keys and sills as dimensioned. (Concrete for Curb Design B6 is not included in this quantity.)
- ⑥ Includes all concrete work and all castings and appurtenances necessary to construct the catch basins as shown and noted.
- ⑦ Permissible L2KT longitudinal joint. See Standard Plan Sheet 5-297.221.
- ⑧ Pipe drains in location shown to be paid for by the lineal foot as a separate item.
- ⑨ Leave a void between junction of bridge railing and curb (1" min.). Fill void with polystyrene.

S.P. 204-113-03 RECORDED PLAN OCT 1993 "MODIFIED" Fig. 5-397.308  
Revised: July 22, 1982 Approved: June 13, 1978

TITLE: BRIDGE APPROACH PANEL ALL SKEWS (BITUMINOUS PAVEMENT)	DES: MnDOT CHK: RLD	DR: MnDOT/GLA CHK: RLD	APPROVED: 7-2-92	Bridge No. 71517
--	------------------------	---------------------------	------------------	------------------