

**EROSION & SEDIMENTATION CONTROL NOTES & DETAILS / "SITE MAP"**

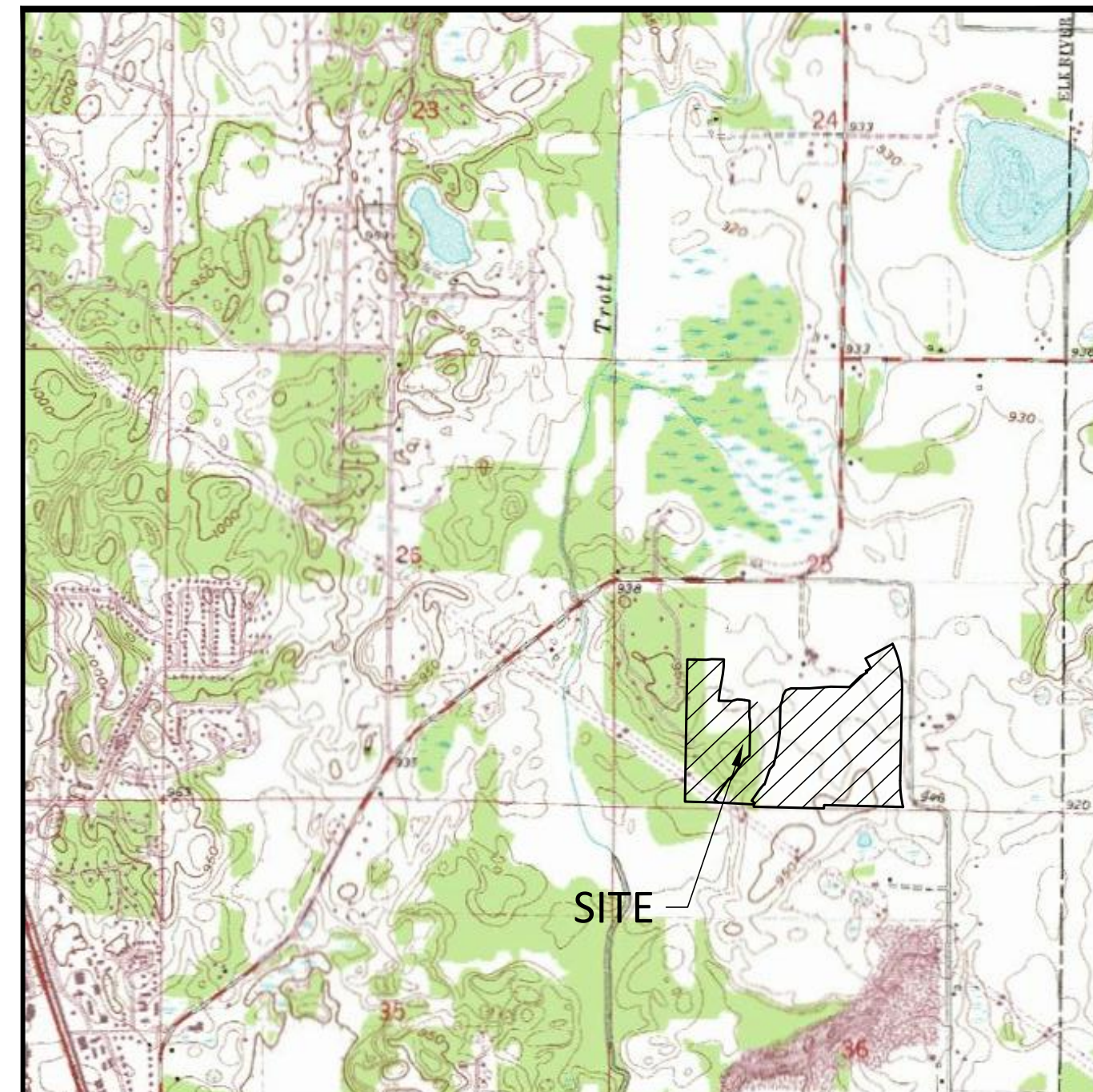
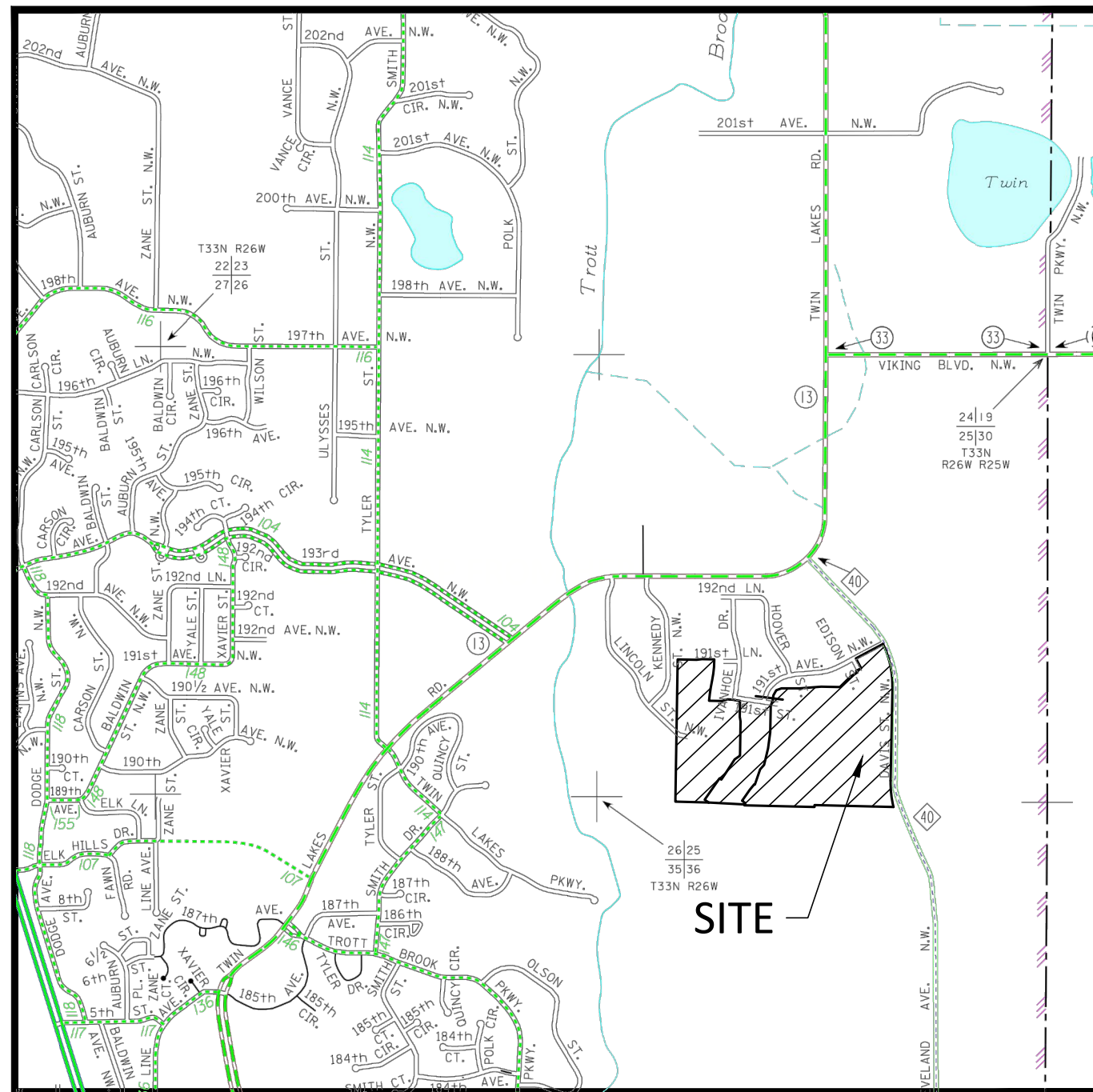

**SITE LOCATION MAP**

NOT TO SCALE

**USGS MAP**

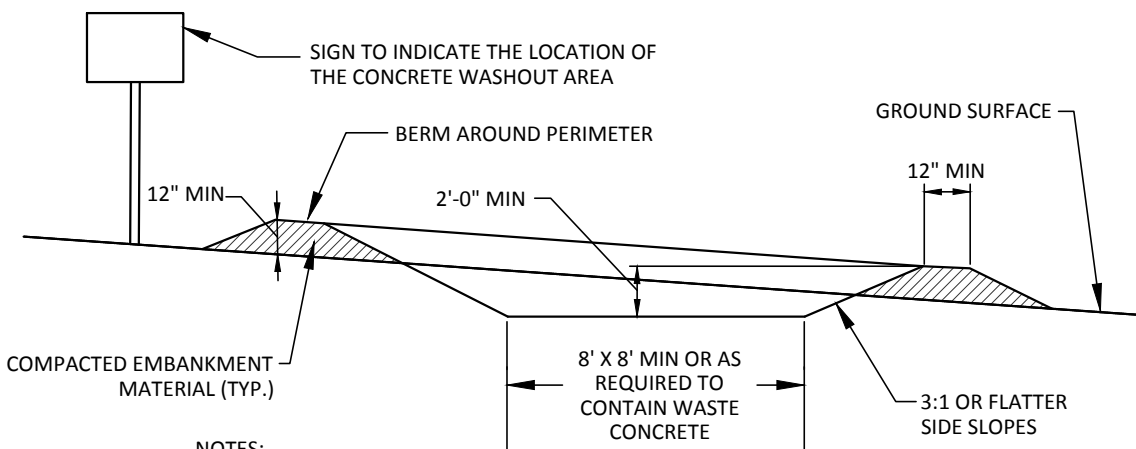

- NOTES:**
1. CONCRETE WASHOUT AREA SHALL BE INSTALLED PRIOR TO ANY CONCRETE PLACEMENT ON SITE.
  2. CONCRETE WASHOUT AREA SHALL BE LINED WITH MINIMUM 10 MIL THICK PLASTIC LINER.
  3. VEHICLE TRACKING CONTROL IS REQUIRED IF ACCESS TO CONCRETE WASHOUT AREA IS OFF PAVEMENT.
  4. SIGNS SHALL BE PLACED AT THE CONSTRUCTION ENTRANCE, AT THE WASHOUT AREA, AND ELSEWHERE AS NECESSARY TO CLEARLY INDICATE THE LOCATION OF THE CONCRETE WASHOUT AREA TO OPERATORS OF CONCRETE TRUCKS AND PUMP RIGS.
  5. THE CONCRETE WASHOUT AREA SHALL BE REPAIRED AND ENLARGED OR CLEANED OUT AS NECESSARY TO MAINTAIN CAPACITY FOR WASTED CONCRETE.
  6. AT THE END OF CONSTRUCTION, ALL CONCRETE SHALL BE REMOVED FROM THE SITE AND DISPOSED OF AT AN ACCEPTED WASTE SITE.
  7. WHEN THE CONCRETE WASHOUT AREA IS REMOVED, THE DISTURBED AREA SHALL BE SEEDED AND MULCHED OR OTHERWISE STABILIZED IN A MANNER ACCEPTED BY THE CITY.

**CONCRETE WASHOUT AREA**

NOT TO SCALE

SEE DETAIL SHEET C9.03

**SILT FENCE INLET PROTECTION (IP-1)**

SEE DETAIL SHEET C9.03

**INLET PROTECTION FOR CATCH BASIN (IP-2)**

SEE DETAIL SHEET C9.03

**27" INFRA SAFE SEDIMENT CONTROL BARRIER (IP-3)**

SEE DETAIL SHEET C9.03

**ROCK CONSTRUCTION ENTRANCE**

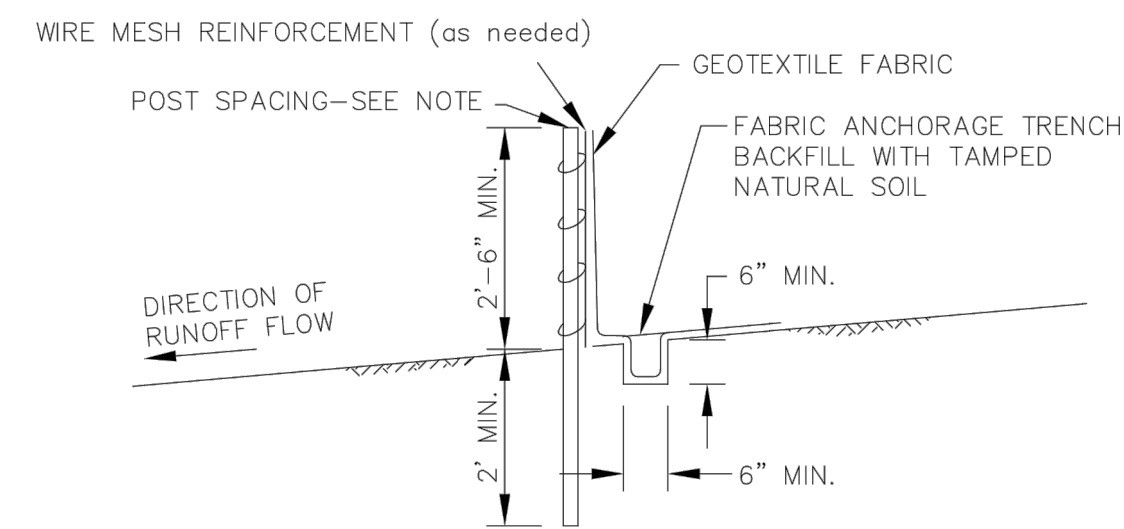

- NOTE:**
1. SILT FENCES CONSTRUCTED WITH SUPPORT FENCES, POSTS SHALL BE SPACED AT 10' OR LESS, AND DRIVEN AT LEAST 2' INTO THE GROUND.
  2. SILT FENCES CONSTRUCTED WITHOUT SUPPORT FENCES, POST SHALL BE SPACED AT 4' OR LESS, AND DRIVEN AT LEAST 3' INTO THE GROUND.

REV: 7/2007

	STANDARD SILT FENCE
	STANDARD PLATE NO. 2009

**GENERAL EROSION NOTES:**

1. CONSTRUCTION SHALL COMPLY WITH ALL APPLICABLE GOVERNING CODES AND BE CONSTRUCTED TO SAME. WHERE A CONFLICT EXISTS BETWEEN LOCAL JURISDICTIONAL STANDARD SPECIFICATIONS AND SAMBATEK STANDARD SPECIFICATIONS, THE MORE STRINGENT SPECIFICATION SHALL APPLY.
2. THE STORMWATER POLLUTION PREVENTION PLAN (SWPPP) IS COMPRISED OF THIS DRAWING (EROSION & SEDIMENTATION CONTROL PLAN-ESC PLAN), THE STANDARD DETAILS, THE PLAN NARRATIVE, AND ITS APPENDICES, PLUS THE PERMIT AND ALL SUBSEQUENT REPORTS AND RELATED DOCUMENTS.
3. CONTRACTOR SHALL BE RESPONSIBLE FOR COMPLETING & SUBMITTING THE APPLICATION FOR THE MPCA GENERAL STORMWATER PERMIT FOR CONSTRUCTION ACTIVITY. ALL CONTRACTORS AND SUBCONTRACTORS INVOLVED WITH STORM WATER POLLUTION PREVENTION SHALL OBTAIN A COPY OF THE SWPPP AND THE STATE OF MINNESOTA NATIONAL POLLUTANT DISCHARGE ELIMINATION SYSTEM GENERAL PERMIT (NPDES PERMIT) AND BECOME FAMILIAR WITH THE CONTENTS. THE SWPPP AND ALL OTHER RELATED DOCUMENTS MUST BE KEPT AT THE SITE DURING CONSTRUCTION.
4. CONTRACTOR SHALL IMPLEMENT BEST MANAGEMENT PRACTICES (BMP'S) AS REQUIRED BY THE SWPPP & PERMITS. CONTRACTOR SHALL OVERSEE THE INSPECTION & MAINTENANCE OF THE BMP'S AND EROSION PREVENTION FROM BEGINNING OF CONSTRUCTION UNTIL CONSTRUCTION IS COMPLETED, IS APPROVED BY ALL AUTHORITIES, AND THE NOTICE OF TERMINATION (NOT) HAS BEEN FILED WITH THE MPCA BY EITHER THE OWNER OR OPERATOR AS APPROVED ON PERMIT. ADDITIONAL BMP'S SHALL BE IMPLEMENTED AS DICTATED BY CONDITIONS AT NO ADDITIONAL COST TO OWNER THROUGHOUT ALL PHASES OF CONSTRUCTION.
5. CONTRACTOR SHALL COMPLY WITH TRAINING REQUIREMENTS IN PART III.A.2 OF THE GENERAL PERMIT.
6. BMP'S AND CONTROLS SHALL CONFORM TO FEDERAL, STATE, OR LOCAL REQUIREMENTS OR MANUAL OF PRACTICE, AS APPLICABLE. CONTRACTOR SHALL IMPLEMENT ADDITIONAL CONTROLS AS DIRECTED BY PERMITTING AGENCY OR OWNER.
7. ESC PLAN MUST CLEARLY DELINEATE ALL STATE WATERS. PERMITS FOR ANY CONSTRUCTION ACTIVITY IMPACTING STATE WATERS OR REGULATED WETLANDS MUST BE MAINTAINED ON SITE AT ALL TIMES.
8. CONTRACTOR SHALL MINIMIZE CLEARING TO THE MAXIMUM EXTENT PRACTICAL OR AS REQUIRED BY THE GENERAL PERMIT. THE BOUNDARIES OF THE CLEARING LIMITS SHOWN ON THE ESC PLANS SHALL BE CLEARLY DELINEATED (E.G. WITH FLAGS, STAKES, SIGNS, SILT FENCE, ETC.) ON THE DEVELOPMENT SITE BEFORE WORK BEGINS. GROUND DISTURBING ACTIVITIES MUST NOT OCCUR OUTSIDE THE LIMITS OF DISTURBANCE.
9. GENERAL CONTRACTOR SHALL DENOTE ON PLAN THE TEMPORARY PARKING AND STORAGE AREA WHICH SHALL ALSO BE USED AS THE EQUIPMENT MAINTENANCE AND CLEANING AREA, EMPLOYEE PARKING AREA, AND AREA FOR LOCATING PORTABLE FACILITIES, OFFICE TRAILERS, AND TOILET FACILITIES.
10. ALL WASH WATER (CONCRETE TRUCKS, VEHICLE CLEANING, EQUIPMENT CLEANING, ETC.) MUST BE LIMITED TO A DEFINED AREA OF THE SITE AND SHALL BE CONTAINED AND PROPERLY TREATED OR DISPOSED. NO ENGINE DEGREASING IS ALLOWED ON SITE.
11. ALL LIQUID AND SOLID WASTES GENERATED BY CONCRETE WASHOUT OPERATIONS MUST BE CONTAINED IN A LEAK-PROOF CONTAINMENT FACILITY OR IMPERMEABLE LINER. THE LIQUID AND SOLID WASTES MUST NOT CONTACT THE GROUND, AND THERE MUST NOT BE RUNOFF FROM THE CONCRETE WASHOUT OPERATIONS OR AREAS. LIQUID AND SOLID WASTES MUST BE DISPOSED OF PROPERLY AND IN COMPLIANCE WITH MPCA REGULATIONS. A SIGN MUST BE INSTALLED ADJACENT TO EACH WASHOUT FACILITY TO INFORM CONCRETE EQUIPMENT OPERATORS TO UTILIZE THE PROPER FACILITIES. SELF-CONTAINED CONCRETE WASHOUTS ON CONCRETE DELIVERY TRUCKS ARE ALLOWED.
12. SUFFICIENT OIL AND GREASE ABSORBING MATERIALS AND FLOTATION BOOMS SHALL BE MAINTAINED ON SITE OR READILY AVAILABLE TO CONTAIN AND CLEAN-UP FUEL OR CHEMICAL SPILLS AND LEAKS.
13. DUST ON THE SITE SHALL BE CONTROLLED. THE USE OF MOTOR OILS AND OTHER PETROLEUM BASED OR TOXIC LIQUIDS FOR DUST SUPPRESSION OPERATIONS IS PROHIBITED.
14. SOLID WASTE: COLLECTED SEDIMENT, ASPHALT & CONCRETE MILLINGS, FLOATING DEBRIS, PAPER, PLASTIC, FABRIC, CONSTRUCTION & DEMOLITION DEBRIS & OTHER WASTES MUST BE DISPOSED OF PROPERLY & MUST COMPLY WITH MPCA DISPOSAL REQUIREMENTS.
15. HAZARDOUS MATERIALS: OIL, GASOLINE, PAINT & ANY HAZARDOUS SUBSTANCES MUST BE PROPERLY STORED, INCLUDING SECONDARY CONTAINMENT, TO PREVENT SPILLS, LEAKS OR OTHER DISCHARGE. RESTRICTED ACCESS TO STORAGE AREAS MUST BE PROVIDED TO PREVENT VANDALISM. STORAGE & DISPOSAL OF HAZARDOUS WASTE MUST BE IN COMPLIANCE WITH MPCA REGULATIONS.
16. ALL STORM WATER POLLUTION PREVENTION MEASURES PRESENTED ON THIS PLAN, AND IN THE SWPPP, SHALL BE INITIATED AS SOON AS PRACTICABLE AND PRIOR TO SOIL DISTURBING ACTIVITIES UPSLOPE.
17. DISTURBED PORTIONS OF THE SITE WHERE CONSTRUCTION ACTIVITY HAS STOPPED SHALL BE TEMPORARILY SEEDED, WITHIN 14 DAYS OF INACTIVITY. SEEDING SHALL BE IN ACCORDANCE WITH MN/DOT SEED MIXTURE NUMBER 21-111 OR 21-112 DEPENDING ON THE SEASON OF PLANTING (SEE MN/DOT SPECIFICATION SECTION 2575.3) SEEDING METHOD AND APPLICATION RATE SHALL CONFORM TO MN/DOT SPECIFICATION SECTION 2575.3. TEMPORARY MULCH SHALL BE APPLIED IN ACCORDANCE WITH MN/DOT SPECIFICATION SECTION 2575.3C1. ALTERNATIVELY, HYDRAULIC SOIL STABILIZER IN ACCORDANCE WITH MN/DOT SPECIFICATION SECTION 2575.3E MAY BE USED IN PLACE OF TEMPORARY MULCH.
18. DISTURBED PORTIONS OF THE SITE WHERE CONSTRUCTION ACTIVITY HAS PERMANENTLY STOPPED SHALL BE PERMANENTLY STABILIZED. THESE AREAS SHALL BE STABILIZED IN ACCORDANCE WITH THE TIME TABLE DESCRIBED ABOVE. REFER TO THE GRADING PLAN AND/OR BASIN SEEDING PLAN FOR VEGETATIVE COVER.
19. CONTRACTORS OR SUBCONTRACTORS WILL BE RESPONSIBLE FOR REMOVING SEDIMENT FROM CONVEYANCES & FROM TEMPORARY SEDIMENTATION BASINS THAT ARE TO BE USED AS PERMANENT WATER QUALITY MANAGEMENT BASINS. SEDIMENT MUST BE STABILIZED TO PREVENT IT FROM BEING WASHED BACK INTO THE BASIN, CONVEYANCES, OR DRAINAGEWAYS DISCHARGING OFF-SITE OR TO SURFACE WATERS. THE CLEANOUT OF PERMANENT BASINS MUST BE SUFFICIENT TO RETURN THE BASIN TO DESIGN CAPACITY.
20. ON-SITE & OFF-SITE SOIL STOCKPILE AND BORROW AREAS SHALL BE PROTECTED FROM EROSION AND SEDIMENTATION THROUGH IMPLEMENTATION OF BMP'S. STOCKPILE AND BORROW AREA LOCATIONS SHALL BE NOTED ON THE SITE MAP AND PERMITTED IN ACCORDANCE WITH GENERAL PERMIT REQUIREMENTS.
21. TEMPORARY SOIL STOCKPILES MUST HAVE SILT FENCE OR OTHER EFFECTIVE SEDIMENT CONTROLS & CANNOT BE PLACED IN SURFACE WATERS, INCLUDING STORMWATER CONVEYANCES SUCH AS CURB & GUTTER SYSTEMS OR CONDUITS & DITCHES.
22. SLOPES SHALL BE LEFT IN A ROUGHENED CONDITION DURING THE GRADING PHASE TO REDUCE RUNOFF VELOCITIES AND EROSION.
23. DUE TO THE GRADE CHANGES DURING THE DEVELOPMENT OF THE PROJECT, CONTRACTOR SHALL BE RESPONSIBLE FOR ADJUSTING THE EROSION CONTROL MEASURES (SILT FENCES, CHECK DAMS, INLET PROTECTION DEVICES, ETC.) TO PREVENT EROSION.
24. ALL CONSTRUCTION SHALL BE STABILIZED AT THE END OF EACH WORKING DAY, THIS INCLUDES BACKFILLING OF TRENCHES FOR UTILITY CONSTRUCTION AND PLACEMENT OF GRAVEL OR BITUMINOUS PAVING FOR ROAD CONSTRUCTION.

**MAINTENANCE NOTES:**

ALL MEASURES STATED ON THIS EROSION AND SEDIMENT CONTROL PLAN, AND IN THE STORM WATER POLLUTION PREVENTION PLAN SHALL BE MAINTAINED IN FULLY FUNCTIONAL CONDITION UNTIL NO LONGER REQUIRED FOR A COMPLETED PHASE OF WORK OR FINAL STABILIZATION OF THE SITE. THE DESIGNATED CONTACT PERSON NOTED ON THIS PLAN MUST ROUTINELY INSPECT THE CONSTRUCTION ON SITE ONCE EVERY SEVEN DAYS DURING ACTIVE CONSTRUCTION AND WITHIN 24 HOURS AFTER A RAINFALL EVENT GREATER THAN 0.5 INCHES IN 24 HOURS. ALL EROSION AND SEDIMENTATION CONTROL MEASURES SHALL BE CLEANED AND REPAIRED IN ACCORDANCE WITH THE FOLLOWING:

1. ALL SILT FENCES MUST BE REPAIRED, REPLACED, OR SUPPLEMENTED WHEN THEY BECOME NONFUNCTIONAL OR THE SEDIMENT REACHES 1/3 OF THE HEIGHT OF THE FENCE. THESE REPAIRS MUST BE MADE WITHIN 24 HOURS OF DISCOVERY, OR AS SOON AS FIELD CONDITIONS ALLOW ACCESS.
2. TEMPORARY AND PERMANENT SEDIMENTATION BASINS MUST BE DRAINED AND THE SEDIMENT REMOVED WHEN THE DEPTH OF SEDIMENT COLLECTED IN THE BASIN REACHES 1/2 THE STORAGE VOLUME. DRAINAGE AND REMOVAL MUST BE COMPLETED WITHIN 72 HOURS OF DISCOVERY, OR AS SOON AS FIELD CONDITIONS ALLOW ACCESS (SEE PART IV.D. OF THE GENERAL PERMIT).
3. SURFACE WATERS, INCLUDING DRAINAGE DITCHES AND CONVEYANCE SYSTEMS, MUST BE INSPECTED FOR EVIDENCE OF SEDIMENT BEING DEPOSITED BY EROSION. CONTRACTOR MUST REMOVE ALL DELTAS AND SEDIMENT DEPOSITED IN SURFACE WATERS, INCLUDING DRAINAGE WAYS, CATCH BASINS, AND OTHER DRAINAGE SYSTEMS, AND RESTABILIZE THE AREAS WHERE SEDIMENT REMOVAL RESULTS IN EXPOSED SOIL. THE REMOVAL AND STABILIZATION MUST TAKE PLACE WITHIN SEVEN (7) DAYS OF DISCOVERY UNLESS PRECLUDED BY LEGAL, REGULATORY, OR PHYSICAL ACCESS CONSTRAINTS. CONTRACTOR SHALL USE ALL REASONABLE EFFORTS TO OBTAIN ACCESS. IF PRECLUDED, REMOVAL AND STABILIZATION MUST TAKE PLACE WITHIN SEVEN (7) CALENDAR DAYS OF OBTAINING ACCESS. CONTRACTOR IS RESPONSIBLE FOR CONTACTING ALL LOCAL, REGIONAL, STATE AND FEDERAL AUTHORITIES AND RECEIVING ANY APPLICABLE PERMITS, PRIOR TO CONDUCTING ANY WORK.
4. CONSTRUCTION SITE VEHICLE EXIT LOCATIONS MUST BE INSPECTED FOR EVIDENCE OF OFF-SITE SEDIMENT TRACKING ONTO PAVED SURFACES. TRACKED SEDIMENT MUST BE REMOVED FROM ALL OFF-SITE PAVED SURFACES, WITHIN 24 HOURS OF DISCOVERY, OR IF APPLICABLE, WITHIN A SHORTER TIME TO MATCH WITH PART IV.C.6 OF THE GENERAL PERMIT.
5. CONTRACTOR IS RESPONSIBLE FOR THE OPERATION AND MAINTENANCE OF TEMPORARY AND PERMANENT WATER QUALITY MANAGEMENT BMP'S, AS WELL AS ALL EROSION PREVENTION AND SEDIMENT CONTROL BMP'S, FOR THE DURATION OF THE CONSTRUCTION WORK AT THE SITE. THE PERMITTEE(S) ARE RESPONSIBLE UNTIL ANOTHER PERMITTEE HAS ASSUMED CONTROL (ACCORDING TO PART II.B.5 OF THE MPCA GENERAL PERMIT) OVER ALL AREAS OF THE SITE THAT HAVE NOT BEEN FINALLY STABILIZED OR THE SITE HAS UNDERGONE FINAL STABILIZATION, AND A (N.O.T.) HAS BEEN SUBMITTED TO THE MPCA.
6. IF SEDIMENT ESCAPES THE CONSTRUCTION SITE, OFF-SITE ACCUMULATIONS OF SEDIMENT MUST BE REMOVED IN A MANNER AND AT A FREQUENCY SUFFICIENT TO MINIMIZE OFF-SITE IMPACTS (E.G., FUGITIVE SEDIMENT IN STREETS COULD BE WASHED INTO STORM SEWERS BY THE NEXT RAIN AND/OR POSE A SAFETY HAZARD TO USERS OF PUBLIC STREETS).
7. ALL INFILTRATION AREAS MUST BE INSPECTED TO ENSURE THAT NO SEDIMENT FROM ONGOING CONSTRUCTION ACTIVITIES IS REACHING THE INFILTRATION AREA AND THESE AREAS ARE PROTECTED FROM COMPACTION DUE TO CONSTRUCTION EQUIPMENT DRIVING ACROSS THE INFILTRATION AREA.



DEVELOPER/OWNER: PAXMAR 3495 NORTHDAL BLVD NW, SUITE 210 COON RAPIDS, MN 55448 763-753-6176
SITE OPERATOR / GENERAL CONTRACTOR
SUPERINTENDENT:

**Sambatek**  
www.sambatek.com  
12800 Whitewater Drive, Suite 300  
Minnetonka, MN 55343  
763.476.6010 telephone  
763.476.8532 facsimile

Engineering | Surveying | Planning | Environmental

**Client**  
**PAXMAR, LLC.**

3495 NORTHDAL BLVD. NW  
SUITE 210  
COON RAPIDS, MN 55448

**Project**  
**MISKE**  
**MEADOWS**  
**FIFTH ADDITION**

**Location**  
**ELK RIVER, MN**

**Certification**

I hereby certify that this plan, specification or report was prepared by me or under my direct supervision and that I am a duly licensed professional ENGINEER under the laws of the state of Minnesota.

*Eric T. Luth*  
Eric T. Luth  
Registration No. 50475 Date: 03/26/2018

If applicable, contact us for a wet signed copy of this plan which is available upon request at Sambatek's, Minnetonka, MN office.

**Summary**

Designed: ETL Drawn: MMQ  
Approved: ETL Initial Issue: 3/26/2018  
Phase: CD'S

**Revision History**

No.	Date	By	Submittal / Revision
06/14/18		MMQ	CONSTRUCTION DOCUMENTS

**Sheet Title**  
**EROSION**  
**CONTROL**  
**DETAILS**

**Sheet No. Revision**  
**C5.02**

**Project No.** 20460.06