

RIP-RAP INSTALLATION

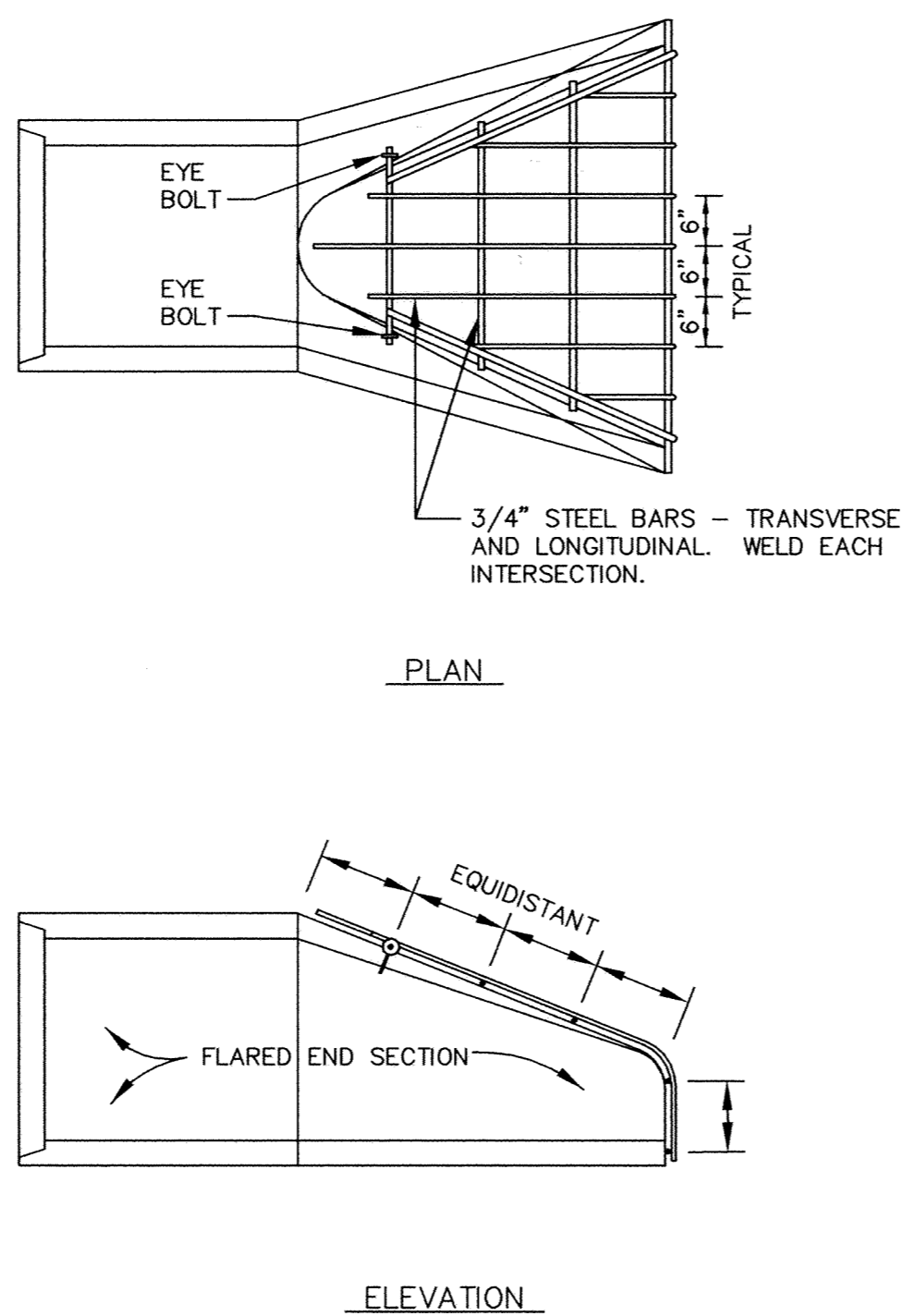

TRASH GUARD

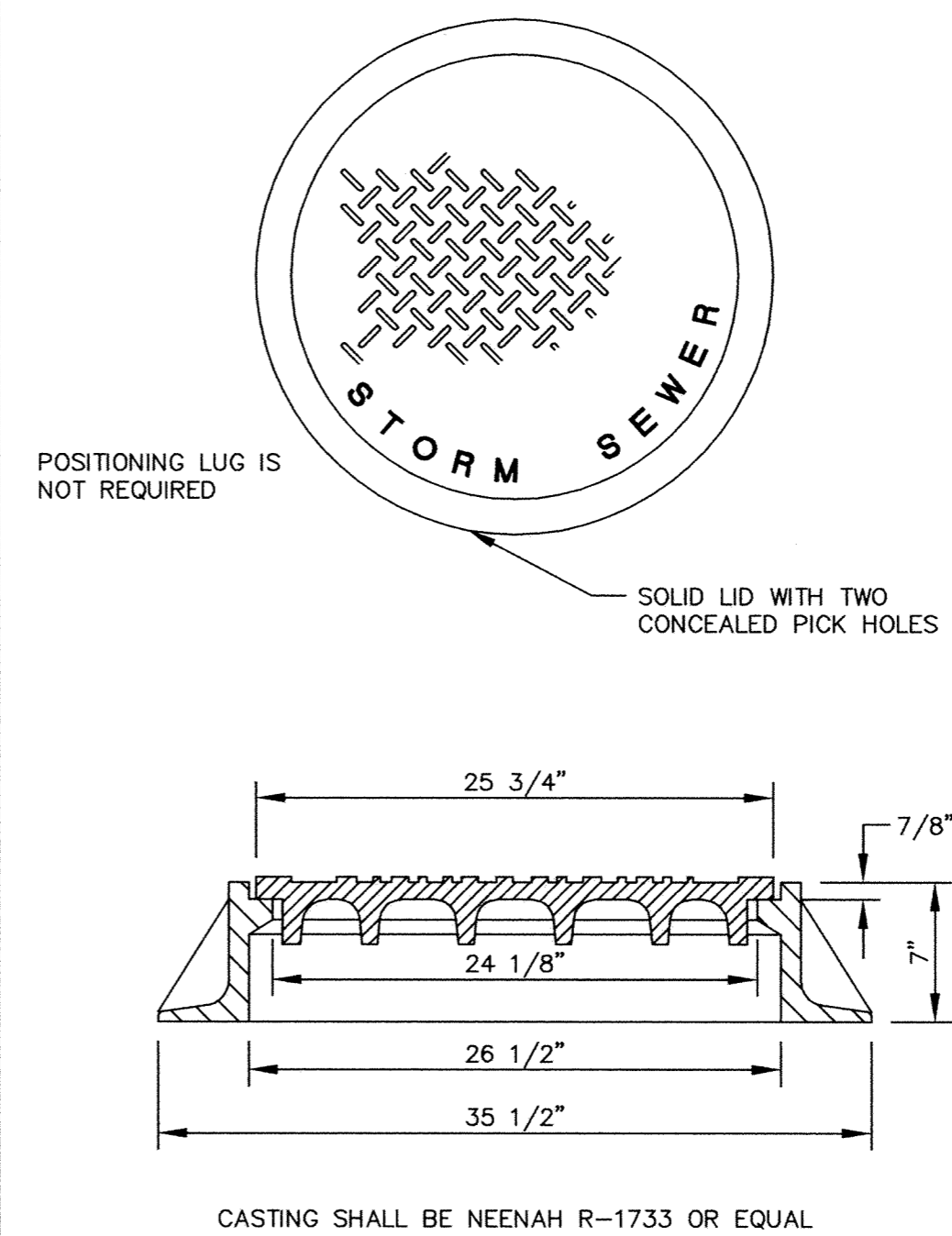

STANDARD MANHOLE CASTING

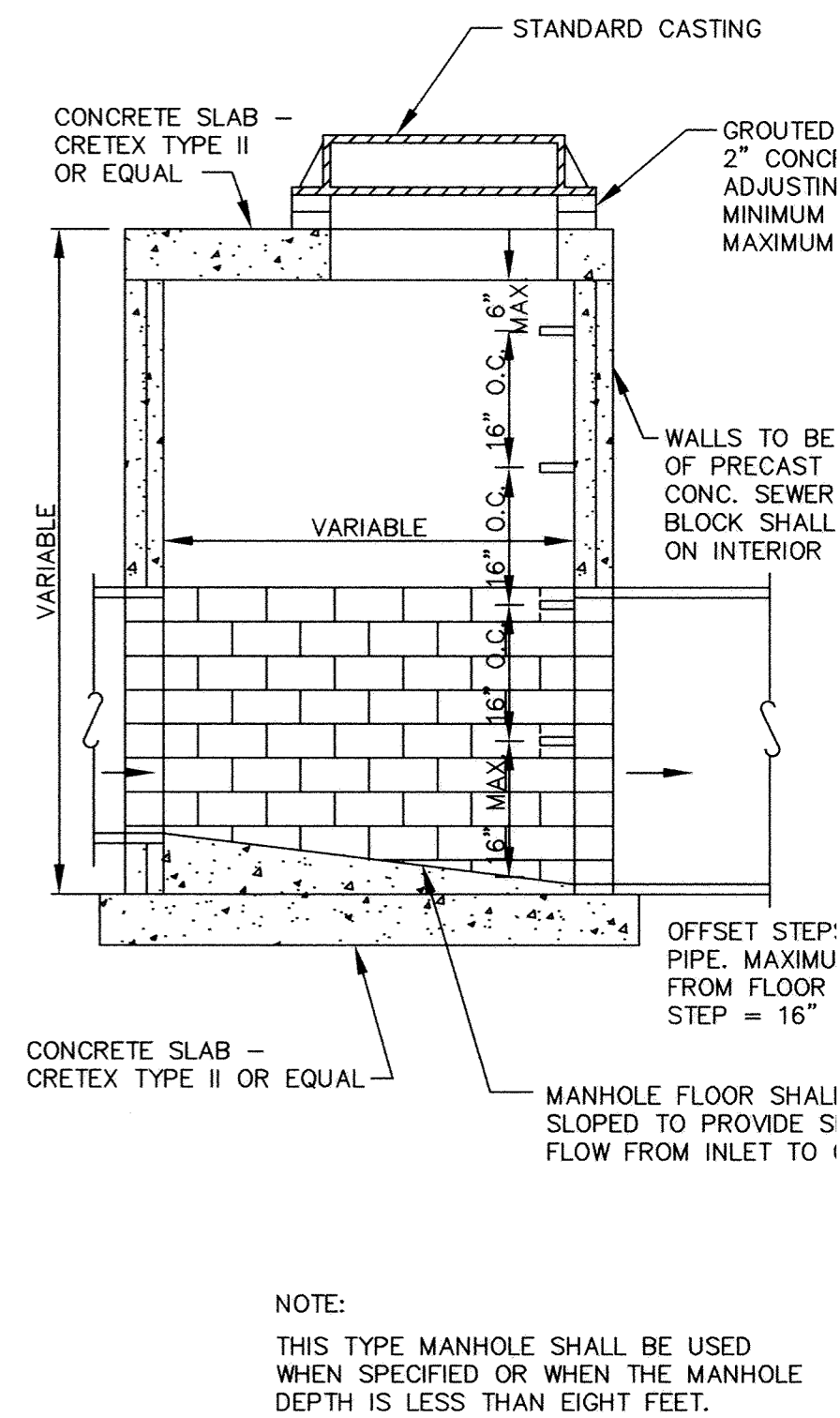

SLAB TOP MANHOLE

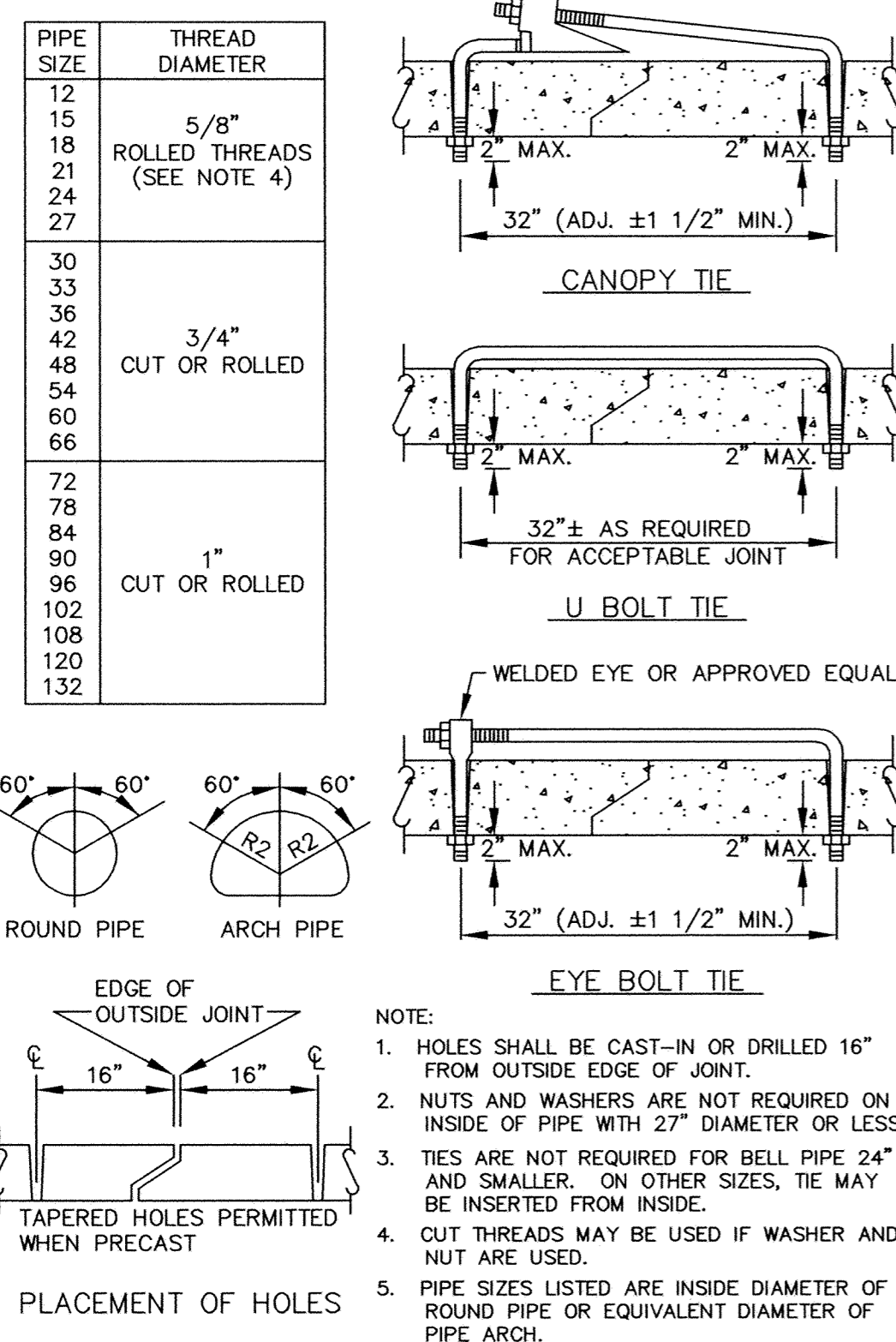

CONCRETE PIPE JOINT TIES

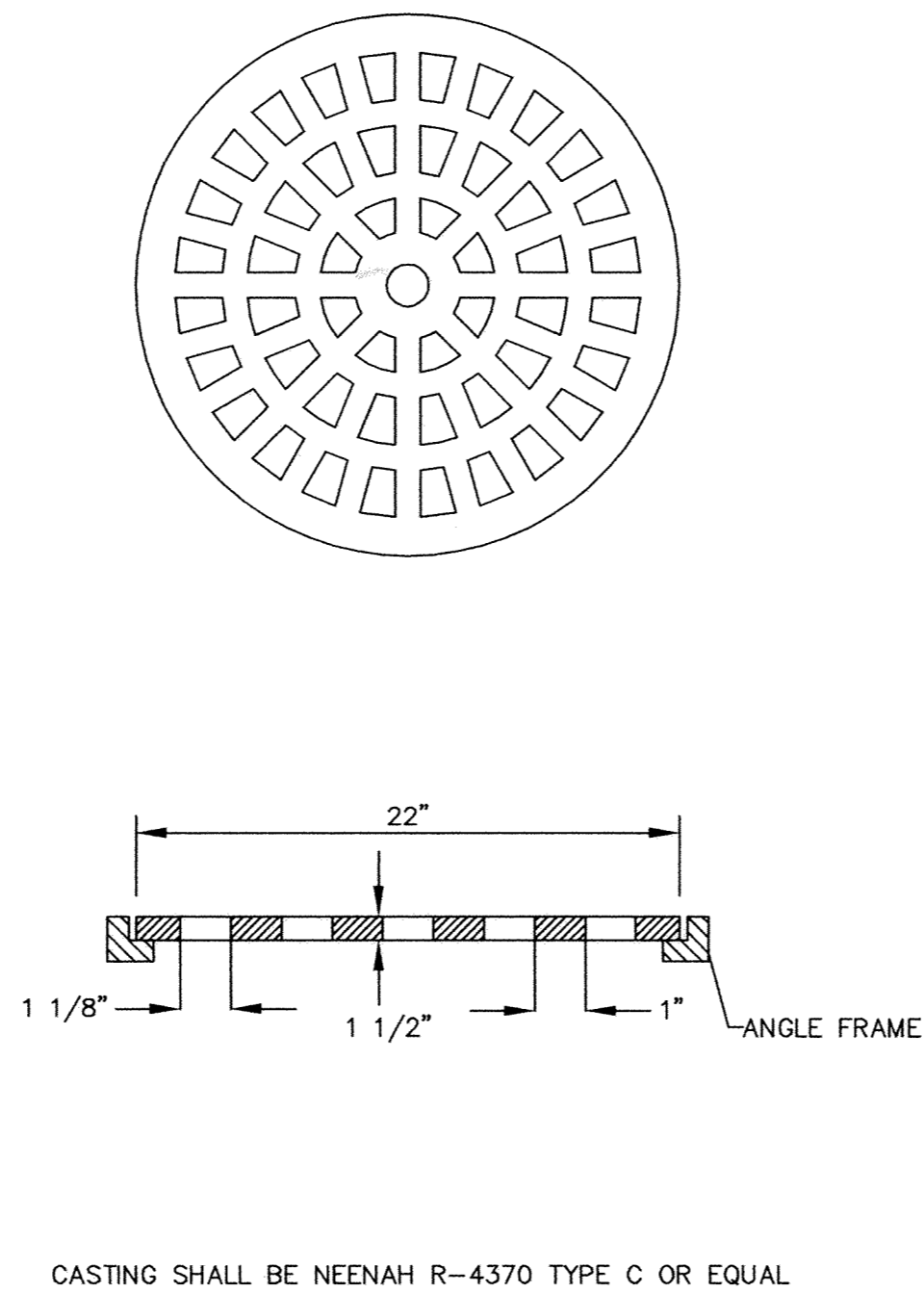

GRATE CASTING

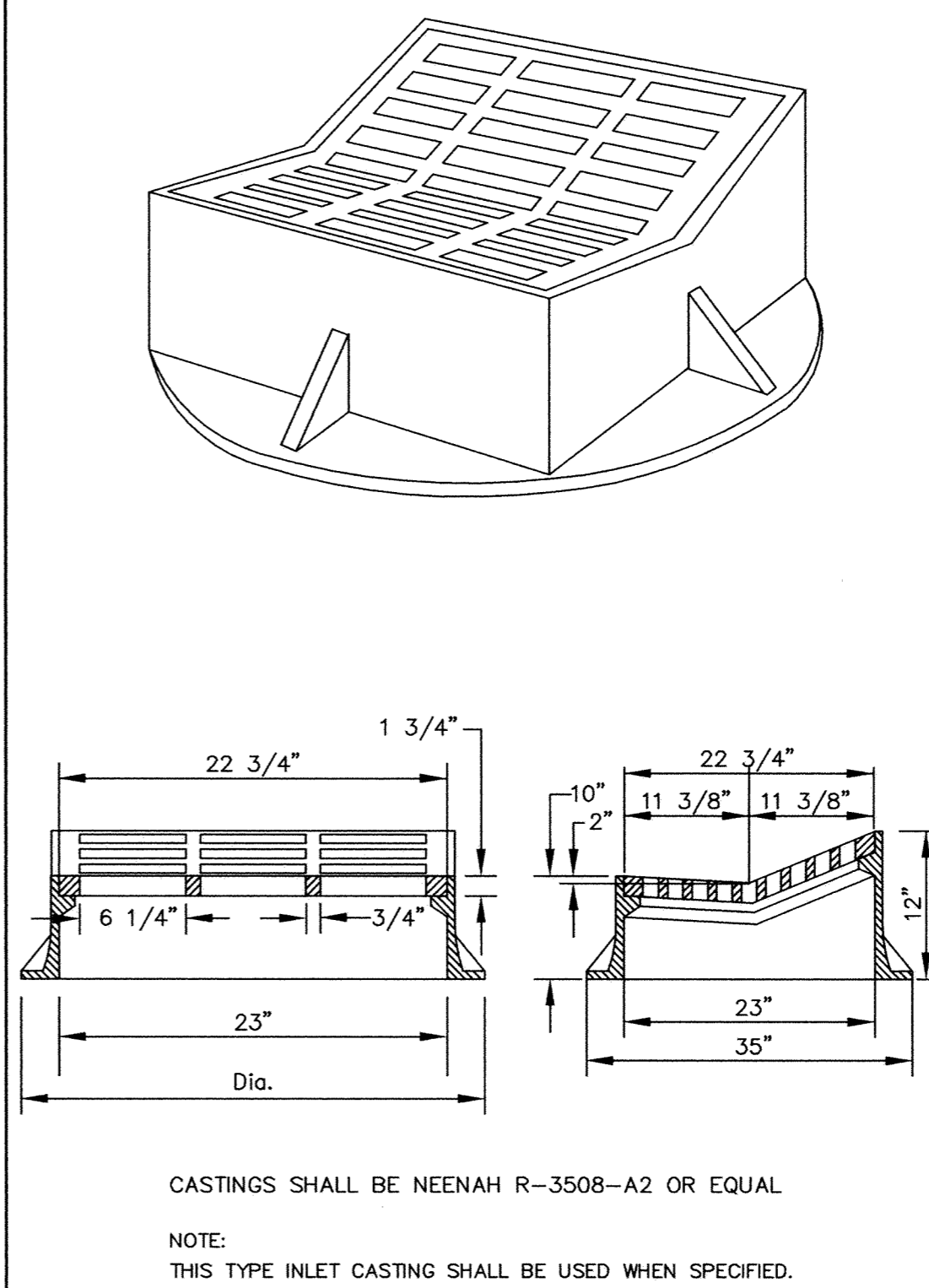

STANDARD INLET CASTING

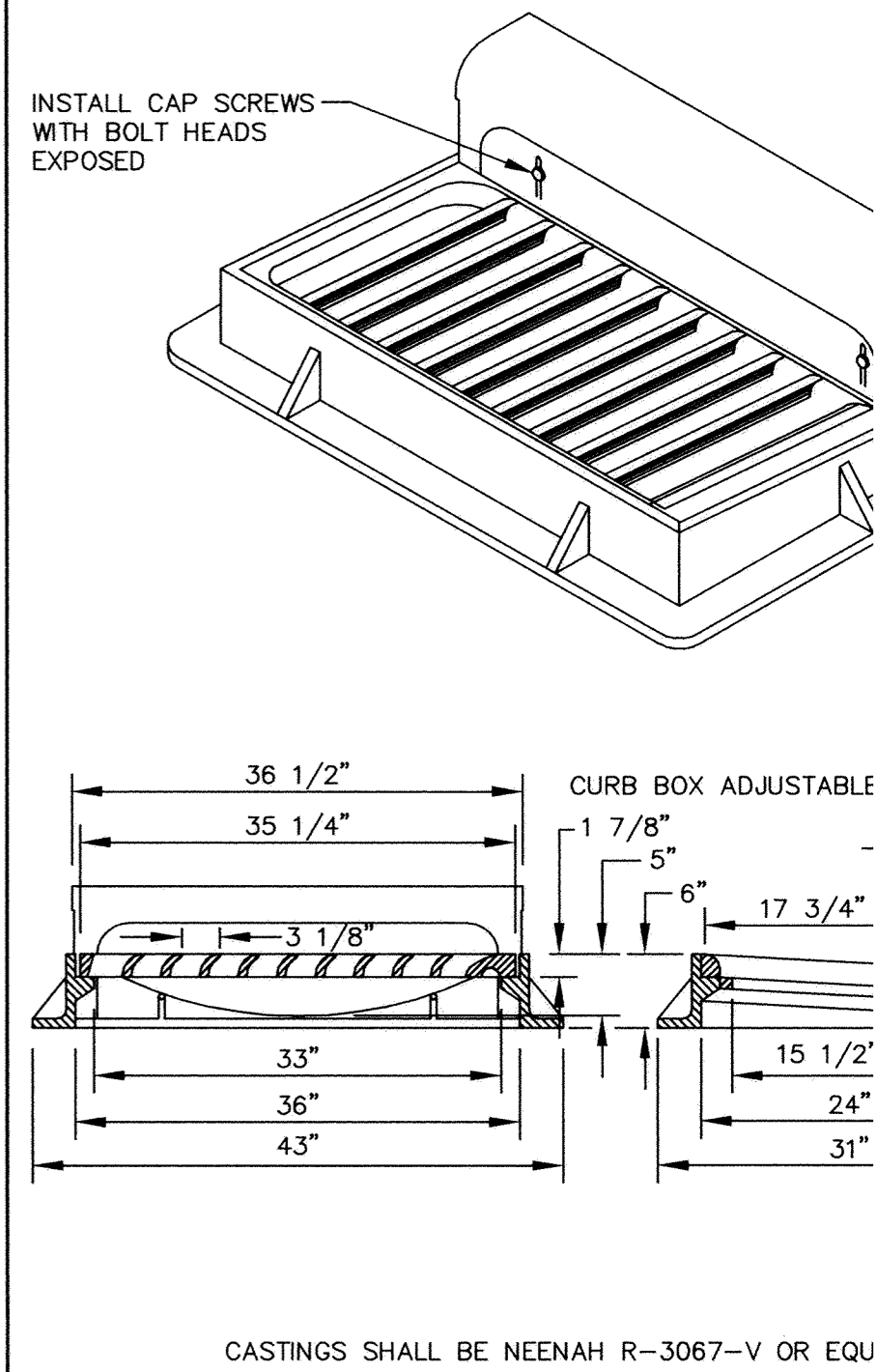

STANDARD INLET CASTING