

**PFE INDEX**

①	SUBMERSIBLE WASTEWATER PUMP (TYP)
②	150mm 90° DISCHARGE CONNECTION
③	200mm x 150mm REDUCER
④	200mm DIP DISCHARGE
⑤	WALL PIPE SUPPORT (2 EACH PIPE DISCHARGE) SEE DETAIL P3
⑥	200mm UNI-FLANGE ADAPTOR OR 200mm FCA
⑦	200mm 90° BEND
⑧	200mm SPOOL
⑨	200mm WALL SLEEVE (FLG-FLG) (4 REQUIRED)
⑩	200mm 90° BEND WITH 13mm TAPPED SS BALL VALVE AND THREADED NIPPLE WITH CAP
⑪	200mm SWING CHECK VALVE
⑫	200mm GATE VALVE WITH HANDWHEEL OPERATOR
⑬	200mm X 200mm X 200mm TEE
⑭	200mm BLIND FLANGE
⑮	350mm X 200mm REDUCER
⑯	350mm X 200mm CROSS
⑰	350mm WALL SLEEVE (FLANGED-MECHANICAL JOINT)
⑱	350mm DIP FORCEMAIN (SEE FORCEMAIN SHT.)
⑲	SEWAGE COMBINATION AIR VALVE HARD PIPED TO TO DRAIN. CONTRACTOR TO SECURE PIPING WITH HANGERS.

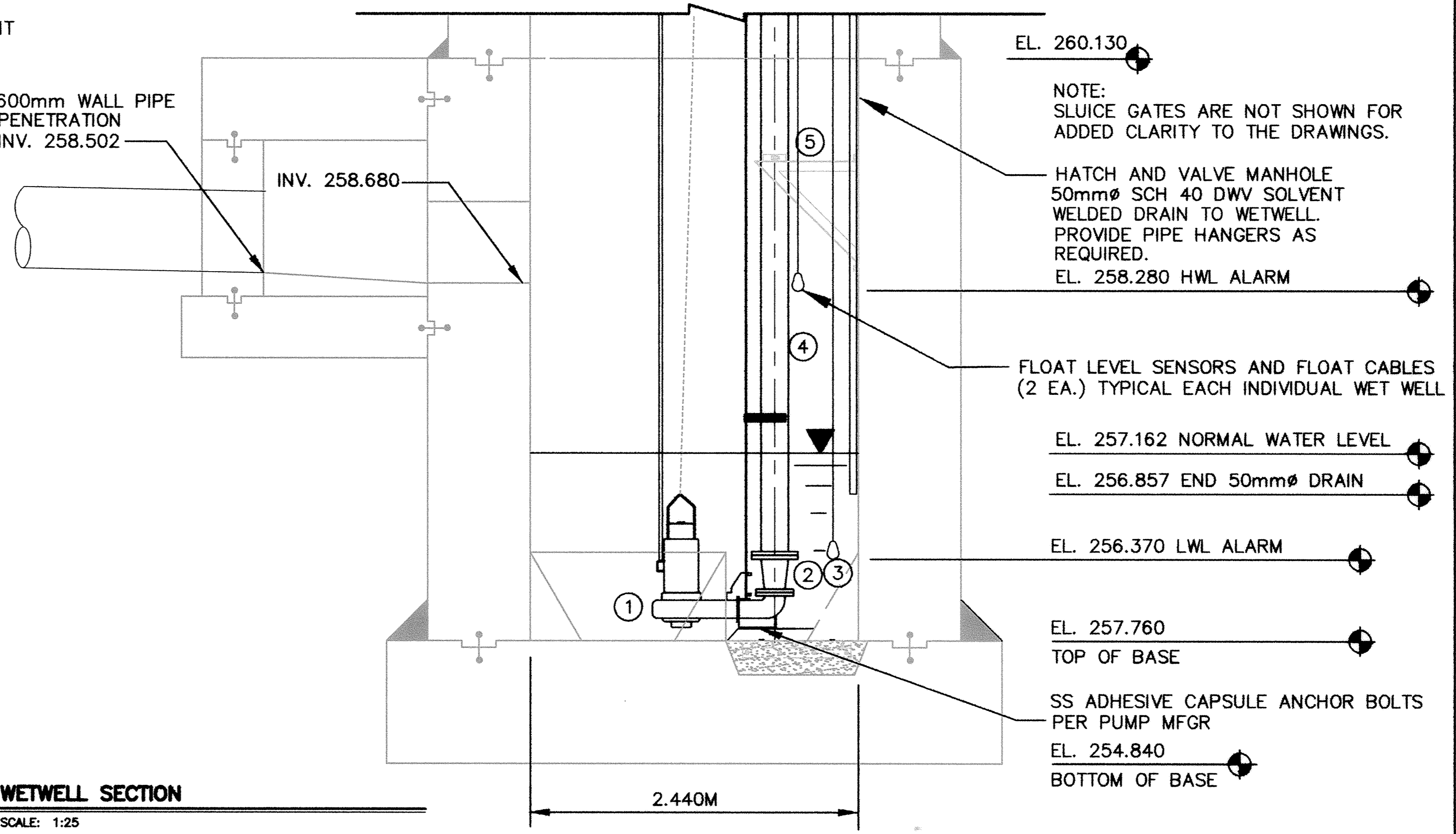

DESIGNED BY: B.G. BELKIN JOB DATE: 8-11-98

DRAWN BY: BEL JOB NUMBER 800110J

CAD DATE: October 06, 1998 4:18:50 p.m.

CAD FILE: 800110\dwg\LIFT\_STATION\P1A.DWG

I HEREBY CERTIFY THAT THIS PLAN, SPECIFICATION, OR REPORT WAS PREPARED BY ME OR UNDER MY DIRECT SUPERVISION AND THAT I AM A FULLY REGISTERED PROFESSIONAL ENGINEER UNDER THE LAWS OF THE STATE OF MINNESOTA.

DATE 10/8/98 REG. NO. 25188

NO.	DATE	BY	REVISION DESCRIPTION

1326 ENERGY PARK DRIVE  
ST. PAUL, MINNESOTA 55108  
(612) 644-4389

**Howard R. Green Company**  
CONSULTING ENGINEERS

**CITY OF ELK RIVER**  
LIFT STATION

**STRUCTURAL SECTIONS**

SHEET NO.  
**LP2**

DRAWING NUMBER  
DRAWING NUMBER  
DRAWING NUMBER  
DRAWING NUMBER

SAFECO PRODUCTS • NEW HAVEN, CONNECTICUT  
REGISTERED BY PART NUMBER 9592

SAFECO PRODUCTS • NEW HAVEN, CONNECTICUT  
REGISTERED BY PART NUMBER 9592

SAFECO PRODUCTS • NEW HAVEN, CONNECTICUT  
REGISTERED BY PART NUMBER 9592

SAFECO PRODUCTS • NEW HAVEN, CONNECTICUT  
REGISTERED BY PART NUMBER 9592