

SAICO PRODUCTS • NEW HOPE, MINNESOTA
REGISTERED BY PART NUMBER 6522
FUNCTION LINE OF PRINT OR THIS LINE

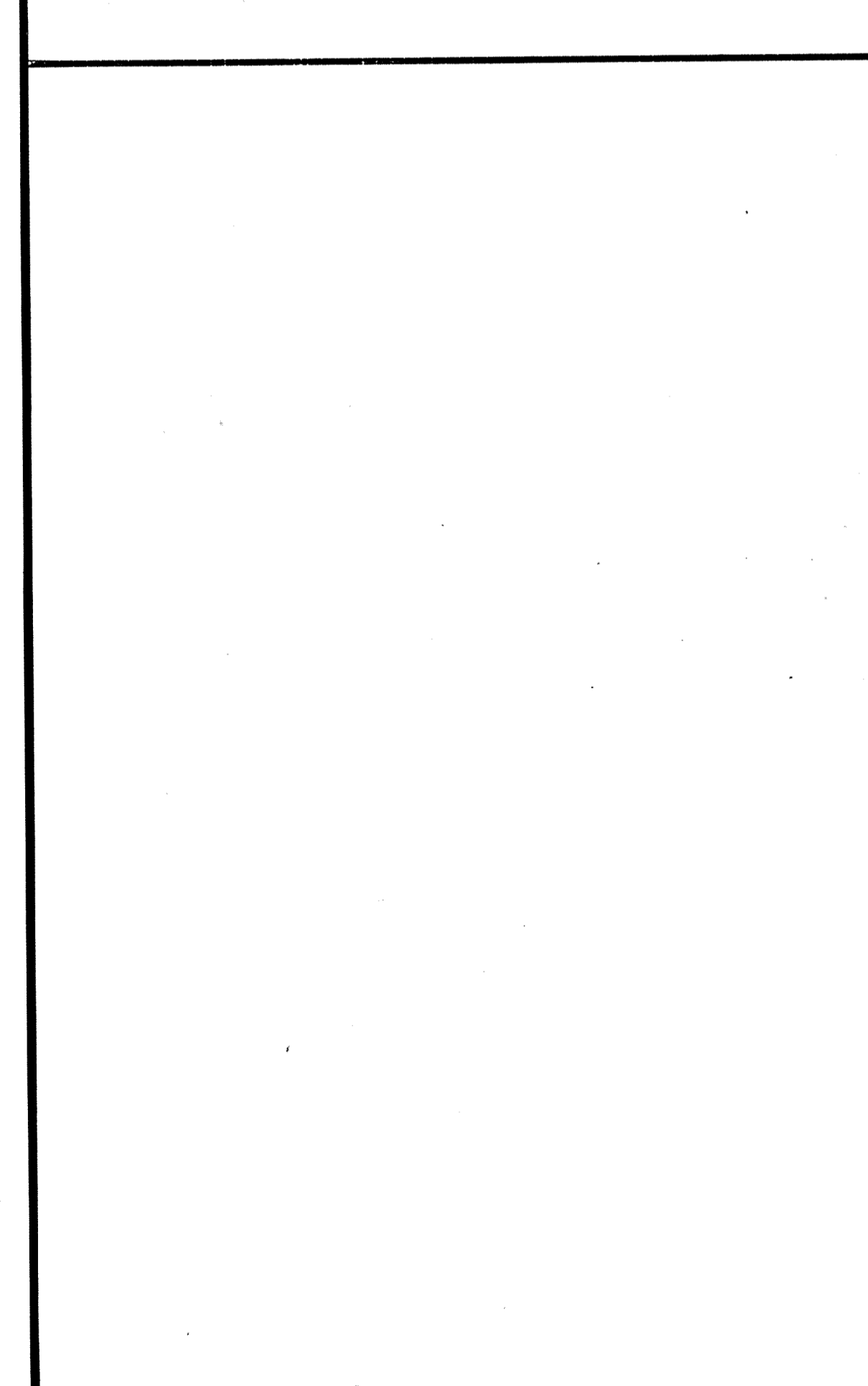
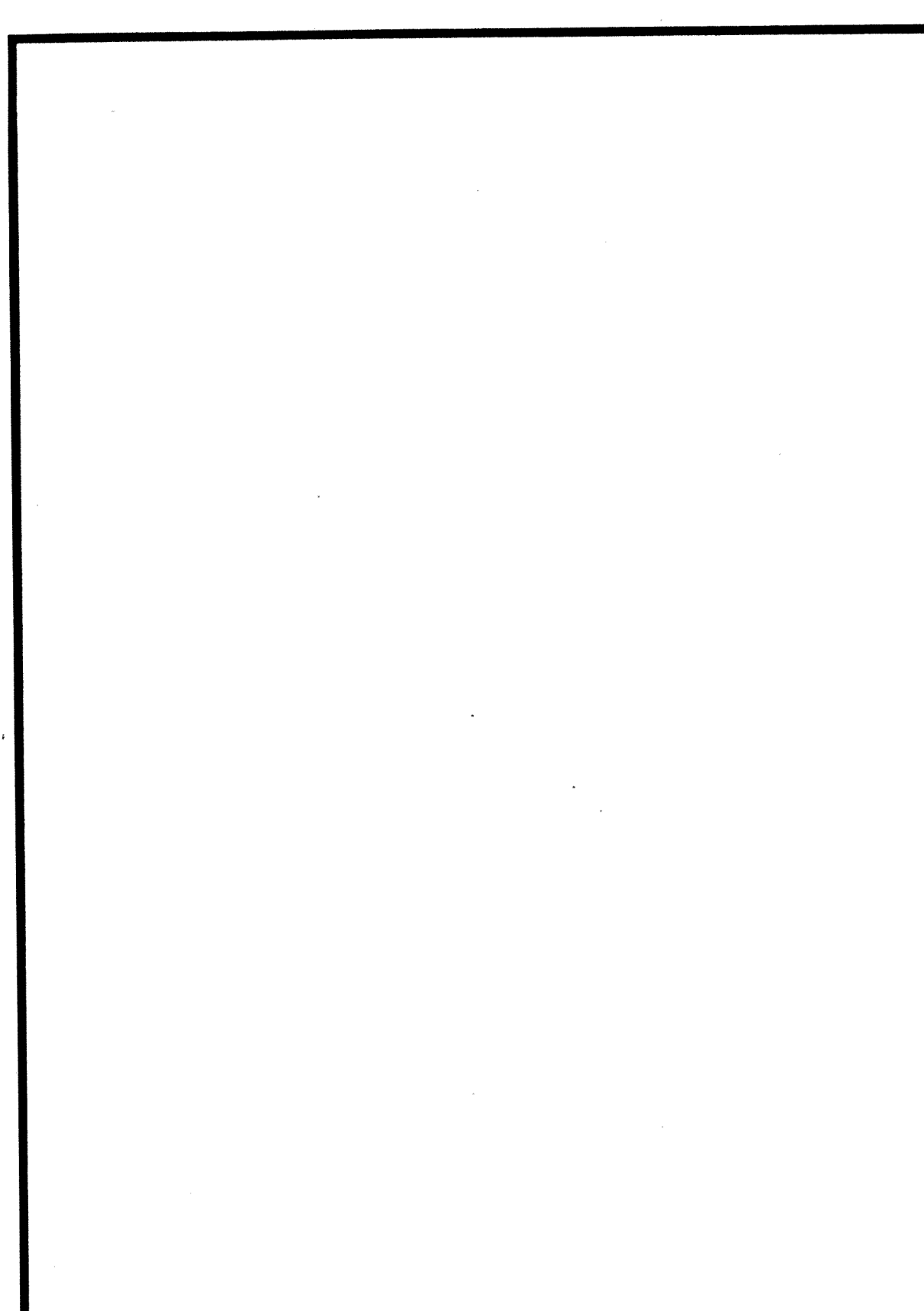
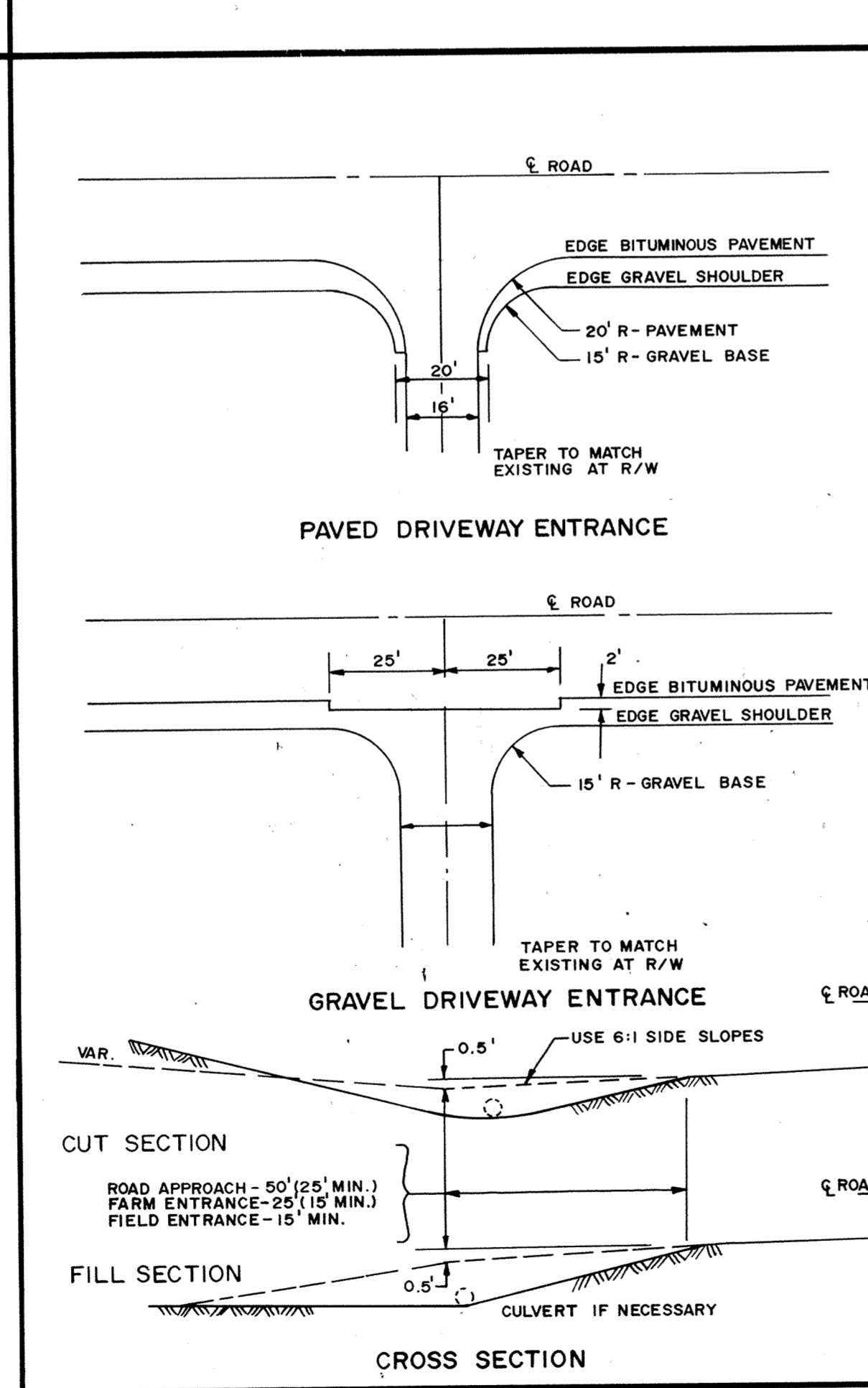
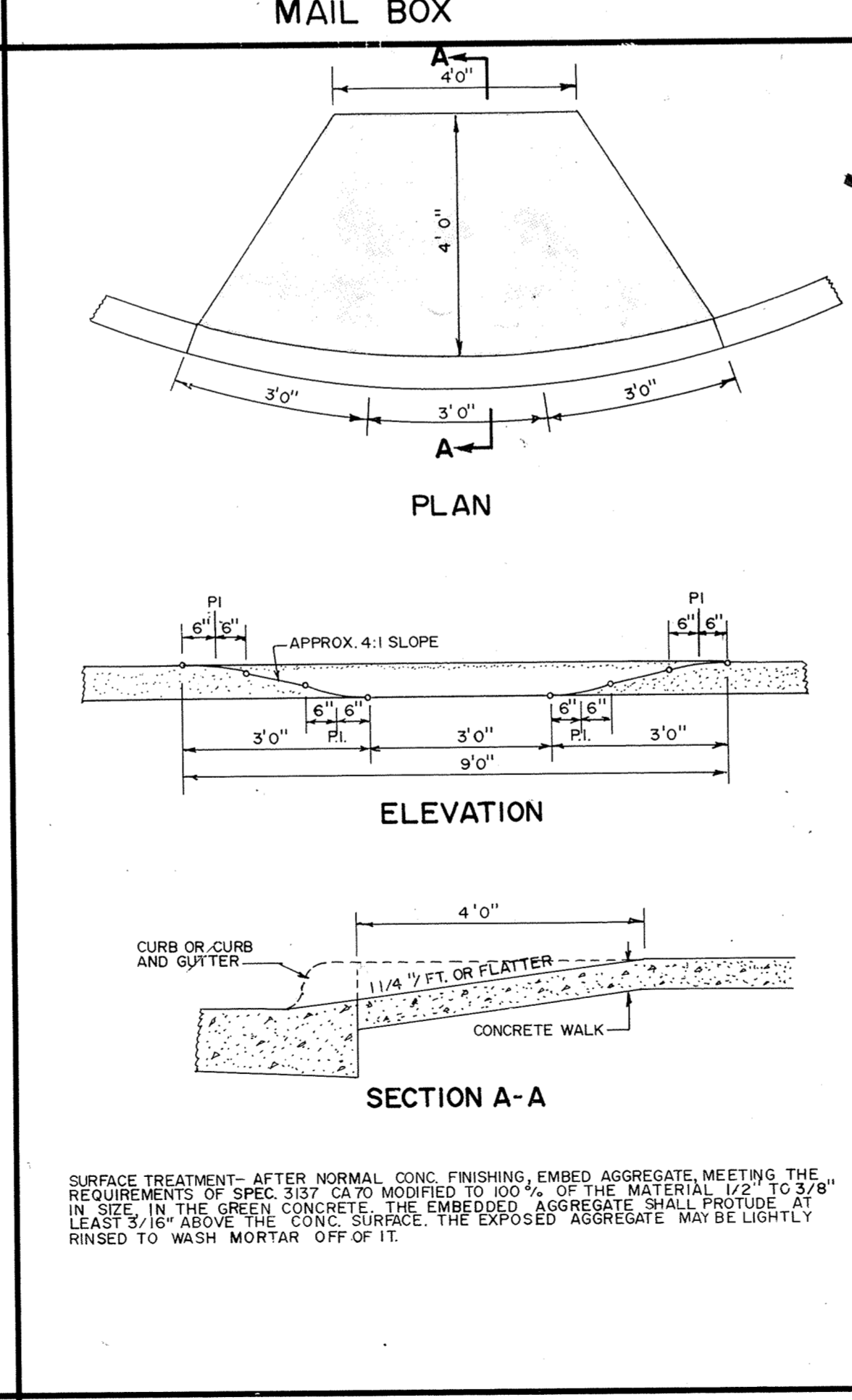
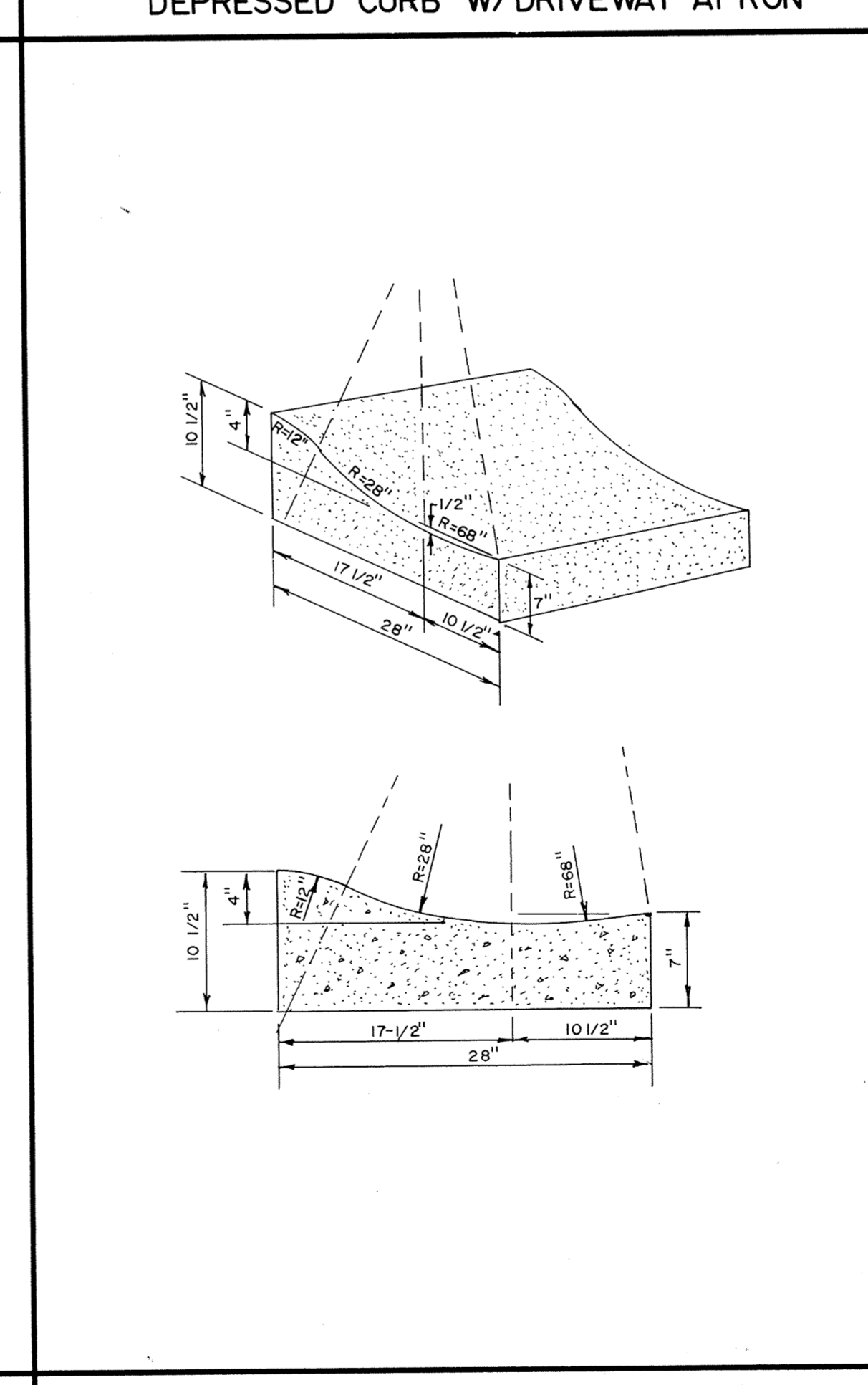
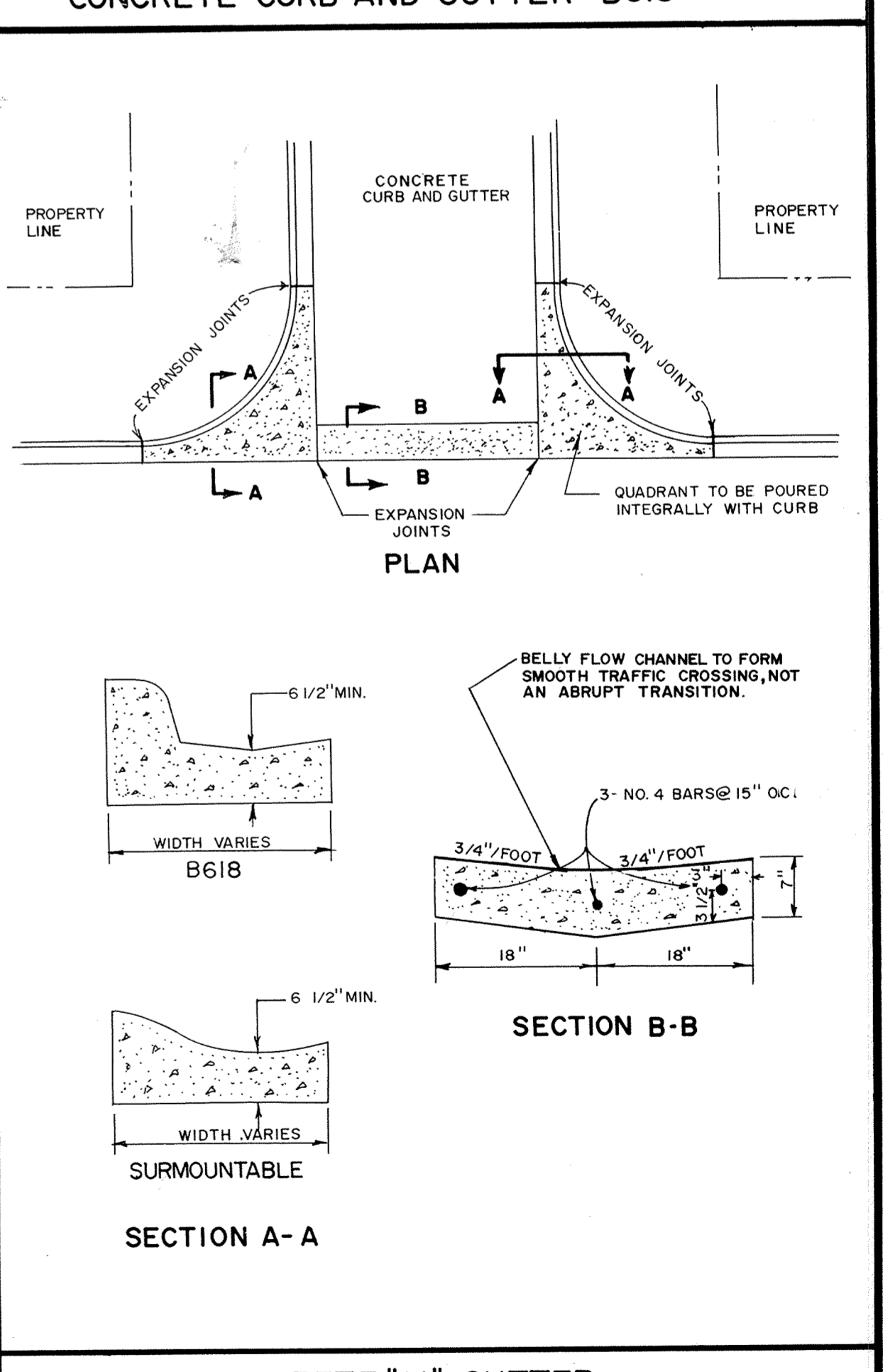
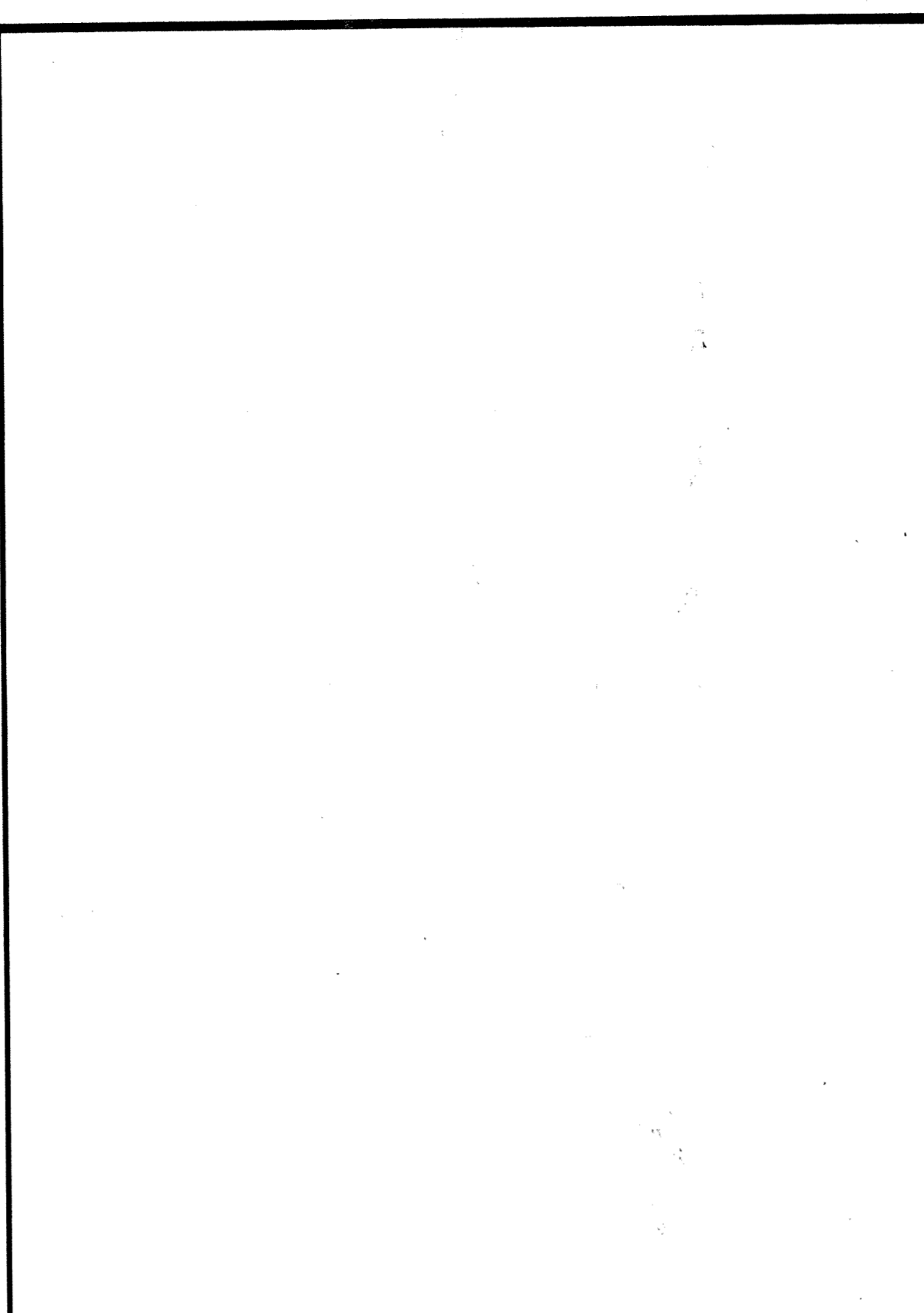
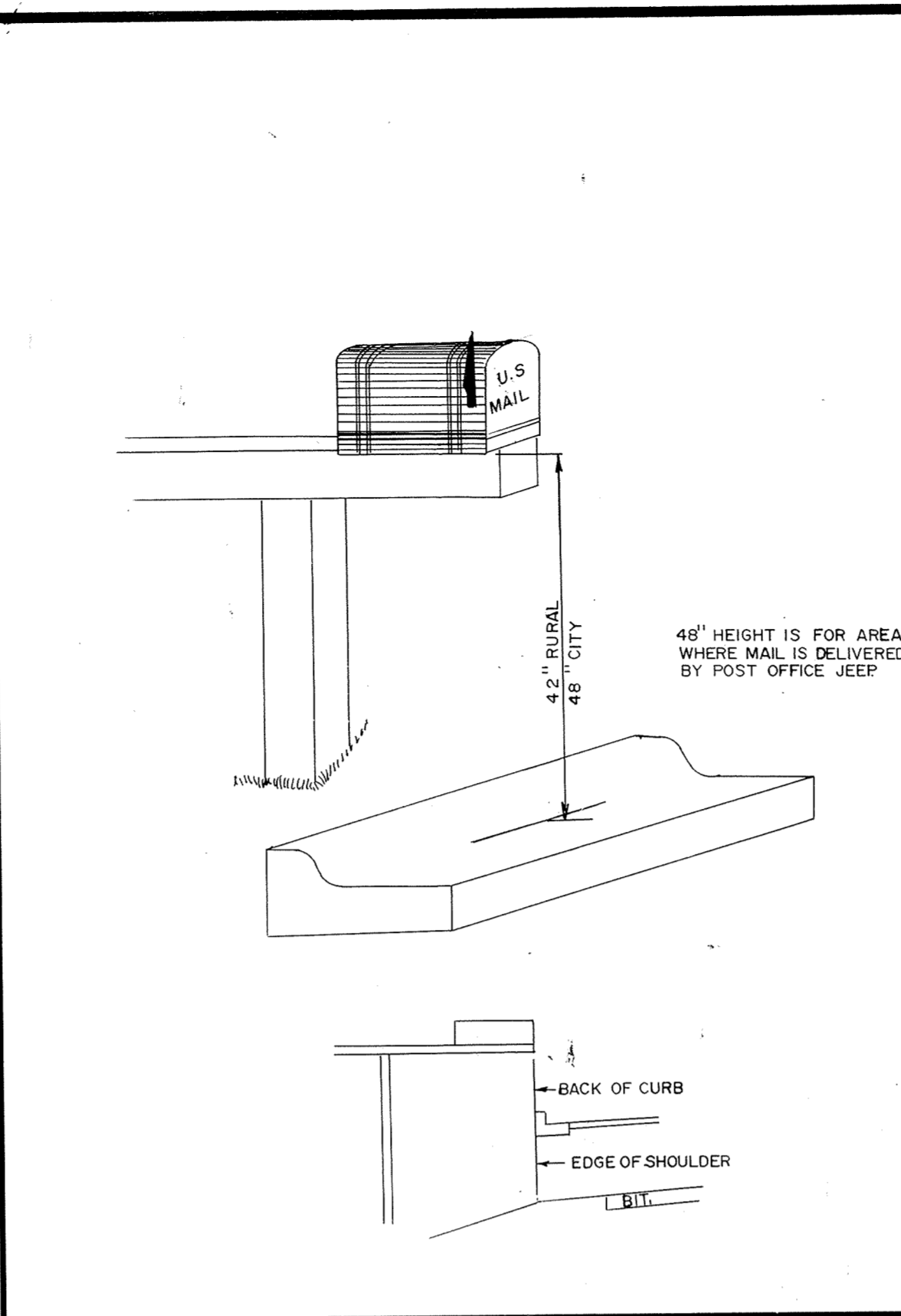
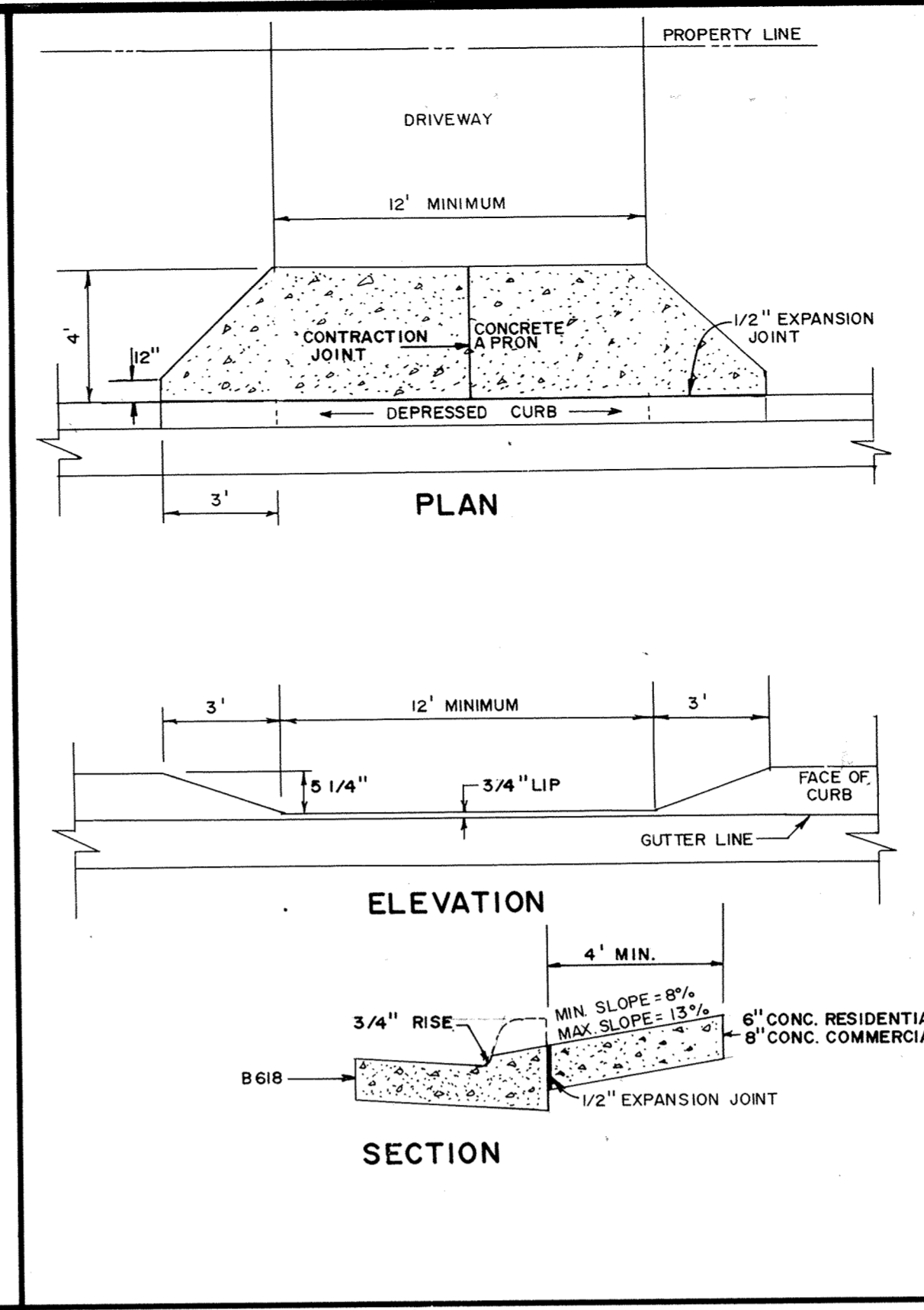
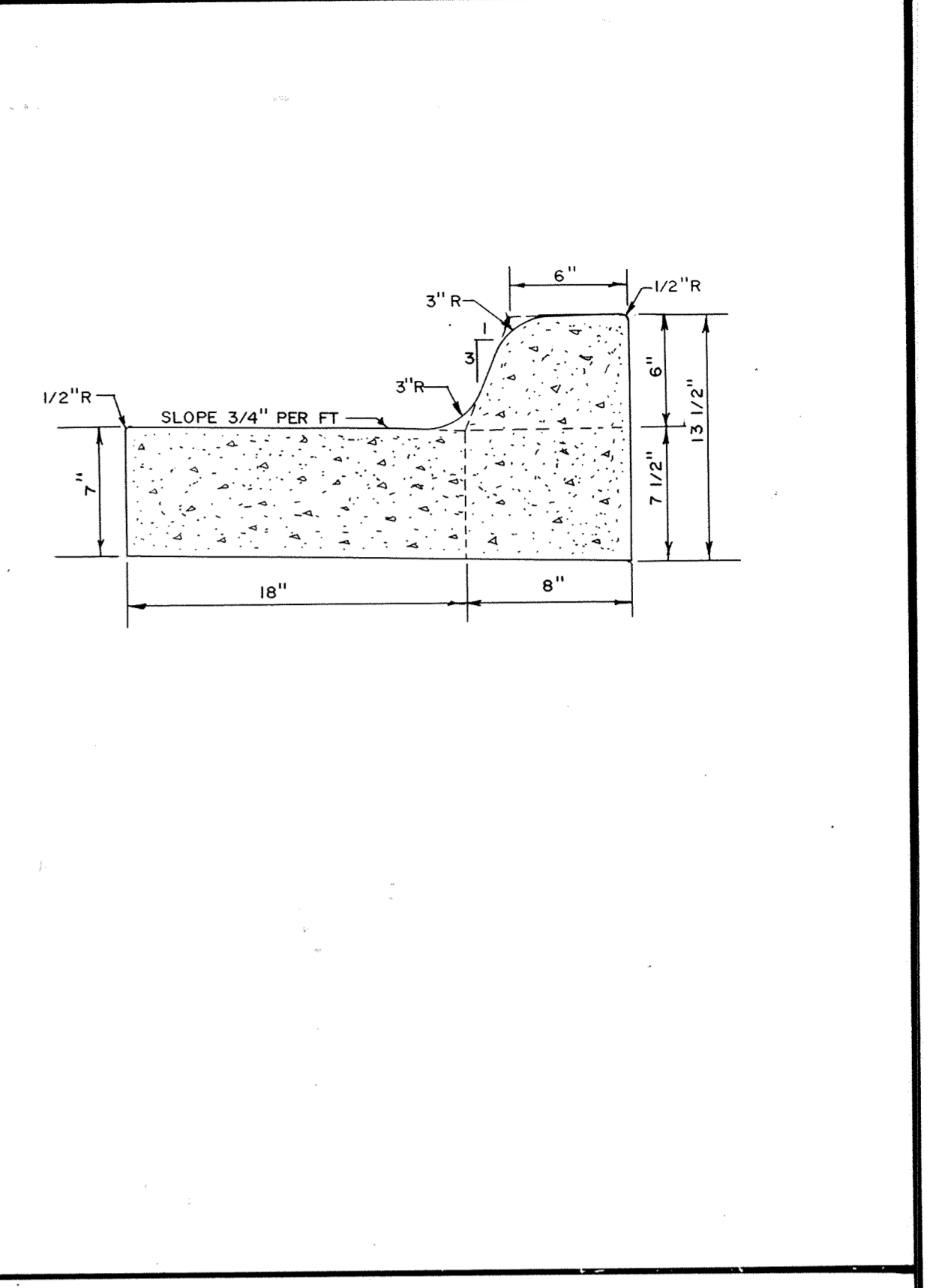

CITY OF ELK RIVER
STREET CONSTRUCTION DETAILS

DATE	JULY 1989
SHEET	16 OF 16 SHEETS
PROJECT NO.	230-073

REVISIONS	DATE	DESCRIPTION	DESIGNED	CHECKED	DRAWN	GRAPHIC SCALE

MSA CONSULTING ENGINEERS
Maier Stewart & Associates Inc.
1959 SLOAN PLACE (612) 774-6021 ST. PAUL, MINNESOTA 55117

ROAD APPROACH - 50' (25' MIN.)
FARM ENTRANCE - 25' (15' MIN.)
FIELD ENTRANCE - 15' MIN.

DESIGNED	
CHECKED	
DRAWN	
GRAPHIC SCALE	
0 HORIZ. NONE	
0 VERT.	