

GARY STREET

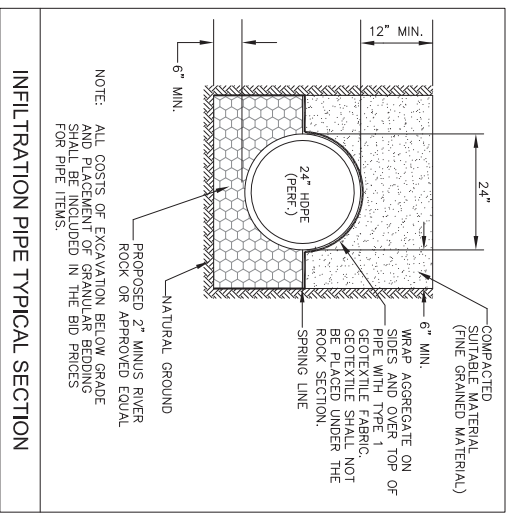
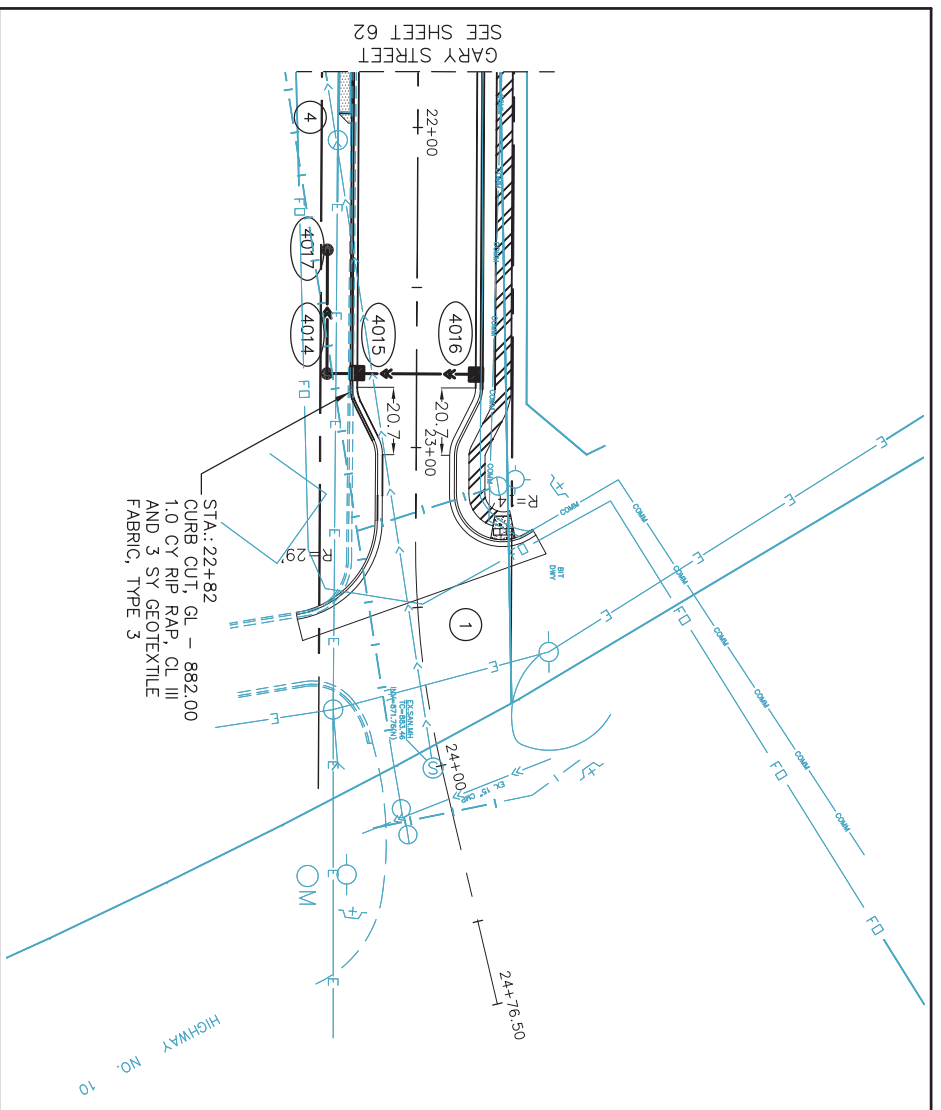

- NEW CONCRETE DRIVEWAY
- NEW BITUMINOUS DRIVEWAY
- NEW BITUMINOUS TRAIL
- NEW CONCRETE APRON
- NEW CONCRETE WALK

- NOTES:
1. ALL MAILBOXES DISTURBED WITH CONSTRUCTION SHALL BE SALVAGED AND REINSTALLED
 2. ALL DRIVEWAYS SHALL BE SAWCUT, REMOVED AND REPLACED TO A DISTANCE NO LESS THAN 5' FROM THE BACK OF CURB OR AS DIRECTED BY THE ENGINEER.
 3. ALL UTILITY CROSSINGS NOT SPECIFIED FOR REMOVAL SHALL BE SUPPORTED DURING CONSTRUCTION AT NO ADDITIONAL COMPENSATION.

- 1 MATCH EXISTING BITUMINOUS SURFACING PER ER-SI-2006
- 2 ADJUST VALVE BOX
- 3 ADJUST CASTING (STORM)
- 4 ADJUST FRAME AND RING CASTING (SANITARY) AND CHIMNEY SEAL
- 5 FURNISH AND INSTALL NEW CASTING
- 6 RECONSTRUCT MANHOLE
- 7 EXCAVATE TO LOCATE SANITARY SEWER SERVICE



900	LOW POINT ELEV=882.30 PVI STA=22+68.49 PVI ELEV=883.03	883.1	882.61	882.9	882.36	882.3	882.34	882.8	882.79	883.7	886.5
895	STA.: 22+25 27.00 R TC=881.50 (48'φ)										
890	STA.: 22+77 27.00 R TC=881.50 (48'φ)										
885	FINISHED PROFILE 1.34%										
880	EXISTING PROFILE										
875	878.90(E) 877.90 SUMP										
870	878.60(W) 878.70(E) 877.70 SUMP										
865	879.10										
860	878.35										

22+00 23+00 24+00

WSB PROJECT NUMBER 1992-01

STREET AND UTILITY PLAN

GARY STREET

SHEET 63 OF 110 SHEETS

701 Xenia Avenue South, Suite 300
Minneapolis, MN 55416
Tel: (763) 541-4800 • Fax: (763) 541-1700
wsbeng.com

engineering • planning • environmental • construction

2013 STREET IMPROVEMENT PROJECT

ELK RIVER, MINNESOTA

I HEREBY CERTIFY THAT THIS PLAN, SPECIFICATION, OR REPORT WAS PREPARED BY ME OR UNDER MY DIRECT SUPERVISION AND THAT I AM A DULY LICENSED PROFESSIONAL ENGINEER UNDER THE LAWS OF THE STATE OF MINNESOTA

Jason C. Wedel
JASON C. WEDEL, P.E.

DATE: MARCH 4, 2013 LIC. NO.: 26768

SCALE:	AS NOTED	REVISION NO. DATE	EXPLANATION
PLAN BY:	ECY	DESIGN BY:	ECY
CHECKED BY:	JCW	PROJECT NO.:	1992-010
RECORD COPY BY:		DATE:	