

NOMINAL FITTING SIZE, INCHES	TEE, WYE, PLUG OR CAP	90° BEND, PLUGGED CROSS	TEE PLUGGED ON RUN		45° BEND	22 1/2" BEND	11 1/4" BEND
			A'	A''			
4	1.0	1.4	1.9	1.4	1.0	—	—
6	2.1	3.0	4.3	3.0	1.6	1.0	—
8	3.8	5.3	7.6	5.4	2.9	1.5	1.0
10	5.9	8.4	11.8	8.4	4.6	2.6	1.2
12	8.5	12.0	17.0	12.0	6.6	3.4	1.7
14	11.5	16.3	23.0	16.3	8.9	4.6	2.3
16	15.0	21.3	30.0	21.3	11.6	6.0	3.0
18	19.0	27.0	38.0	27.0	14.6	7.6	3.8
20	23.5	33.3	47.0	33.3	18.1	9.4	4.7
24	34.0	48.0	68.0	48.0	26.2	13.6	6.8

- NOTE:
1. CONCRETE THRUST BLOCKING TO BE POURED AGAINST UNDISTURBED EARTH.
  2. KEEP CONCRETE CLEAR OF JOINT AND ACCESSORIES.
  3. IF NOT SHOWN ON PLANS, REQUIRED BEARING AREAS AT FITTING SHALL BE AS INDICATED ABOVE, ADJUSTED IF NECESSARY TO CONFORM TO THE TEST PRESSURE (S) AND ALLOWABLE SOIL BEARING STRESS (ES).
  4. BEARING AREAS AND SPECIAL BLOCKING DETAILS SHOWN ON PLANS TAKE PRECEDENCE OVER BEARING AREAS AND BLOCKING DETAILS SHOWN THIS STANDARD DETAIL.
  5. ABOVE BEARING AREAS BASED ON TEST PRESSURE OF 150 P.S.I. AND AN ALLOWABLE SOIL BEARING STRESS OF 2000 POUNDS PER SQUARE FOOT. TO COMPUTE BEARING AREAS FOR DIFFERENT TEST PRESSURES AND SOIL BEARING STRESSES, USE THE FOLLOWING EQUATION: BEARING AREA = (TEST PRESSURE / 150) x (2000 / SOIL BEARING STRESS) x (TABLE VALUE)

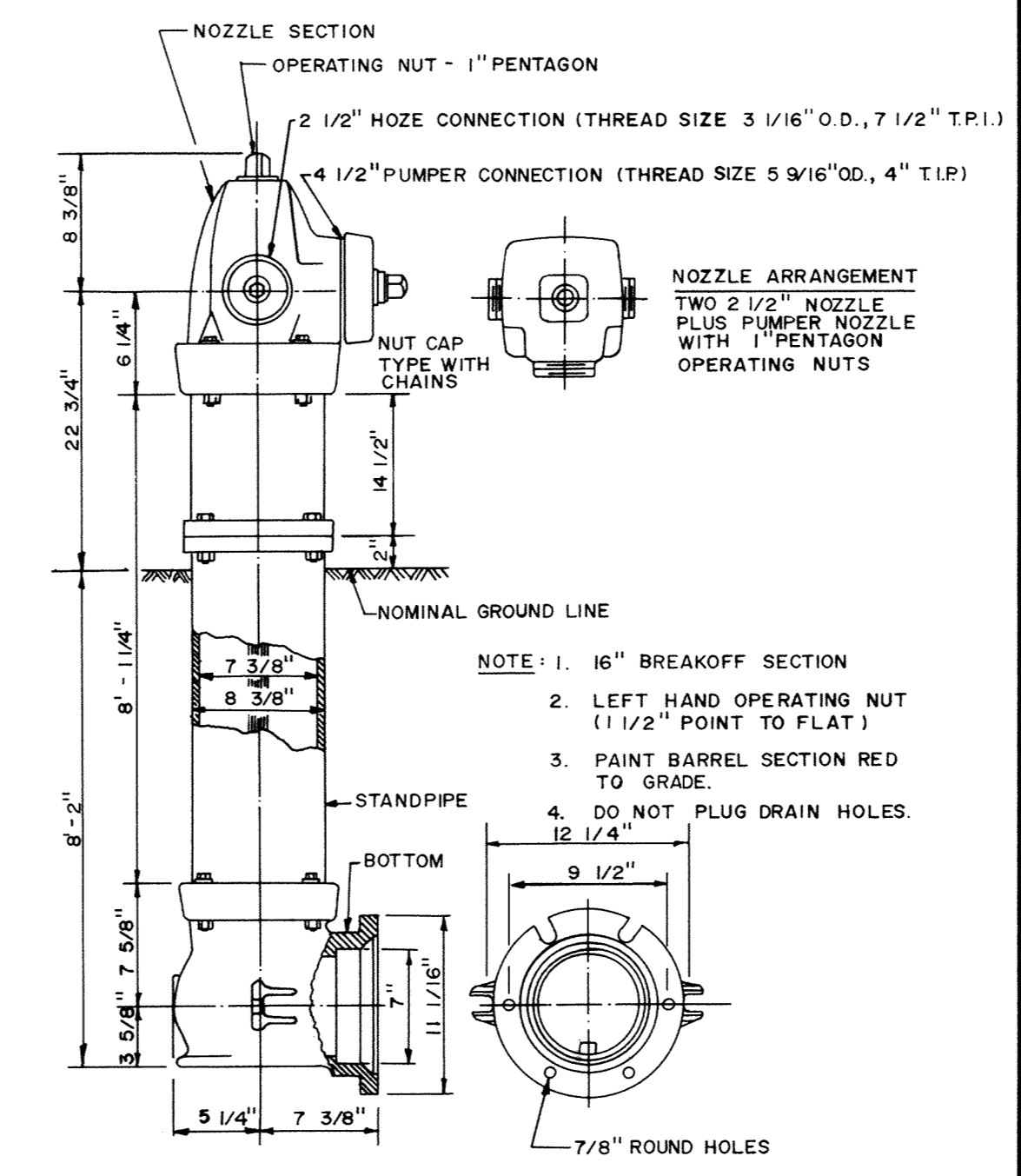

- NOTE:
1. 16" BREAKOFF SECTION
  2. LEFT HAND OPERATING NUT (1 1/2" POINT TO FLAT)
  3. PAINT BARREL SECTION RED TO GRADE.
  4. DO NOT PLUG DRAIN HOLES.

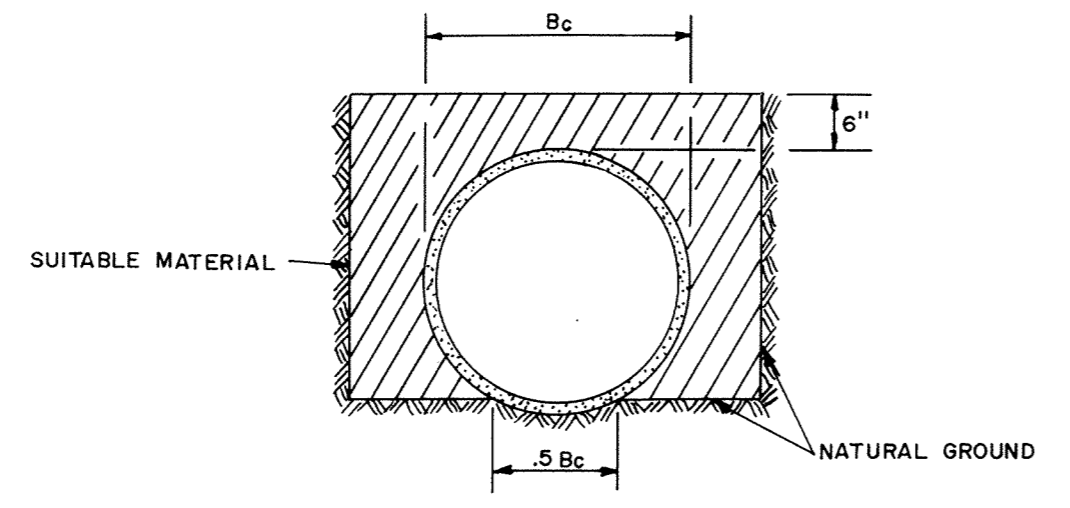
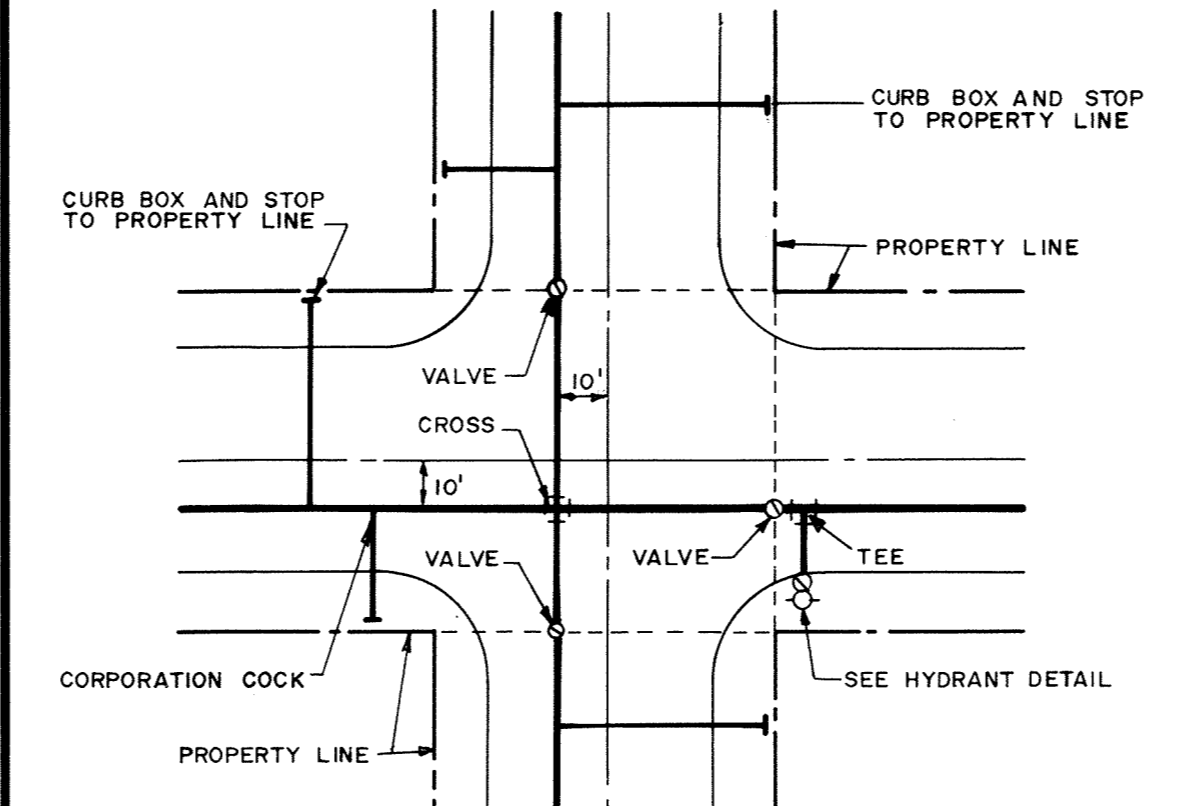

THE BOTTOM OF THE TRENCH SHALL BE SHAPED TO FIT THE PIPE BARREL FOR AT LEAST 50% OF THE OUTSIDE DIAMETER. THE REMAINDER OF THE PIPE IS SURROUNDED TO A HEIGHT OF AT LEAST 6" ABOVE ITS TOP BY SELECT FILL MATERIALS, PLACED BY HAND TOOLS AND COMPACTED TO COMPLETELY FILL ALL SPACES UNDER AND ADJACENT TO THE PIPE.

NOTE: ALL COSTS OF EXCAVATION BELOW GRADE AND PLACEMENT OF GRANULAR BEDDING SHALL BE INCLUDED IN THE BID PRICES FOR PIPE ITEMS.

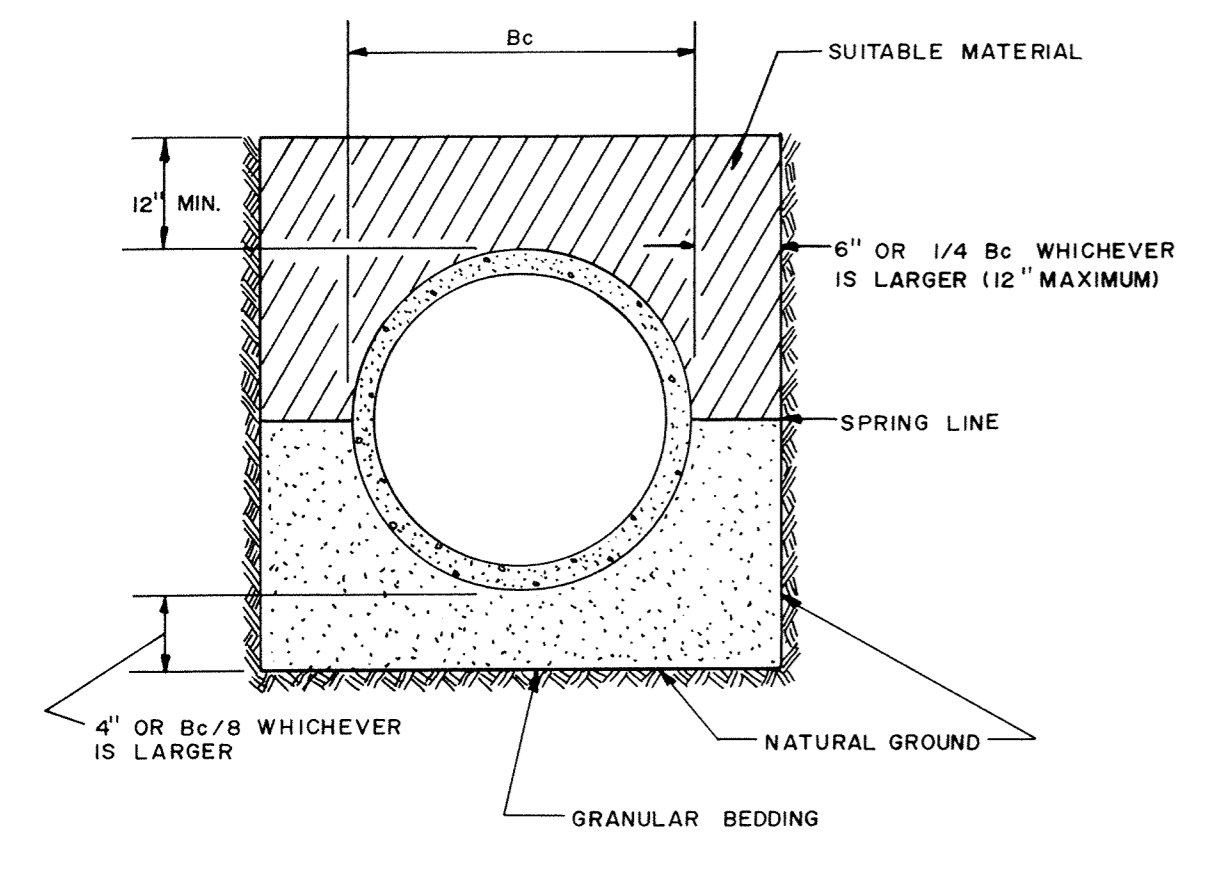

NOTE: ALL COSTS OF EXCAVATION BELOW GRADE AND PLACEMENT OF GRANULAR BEDDING SHALL BE INCLUDED IN THE BID PRICES FOR PIPE ITEMS.

THRUST BLOCKING DETAIL

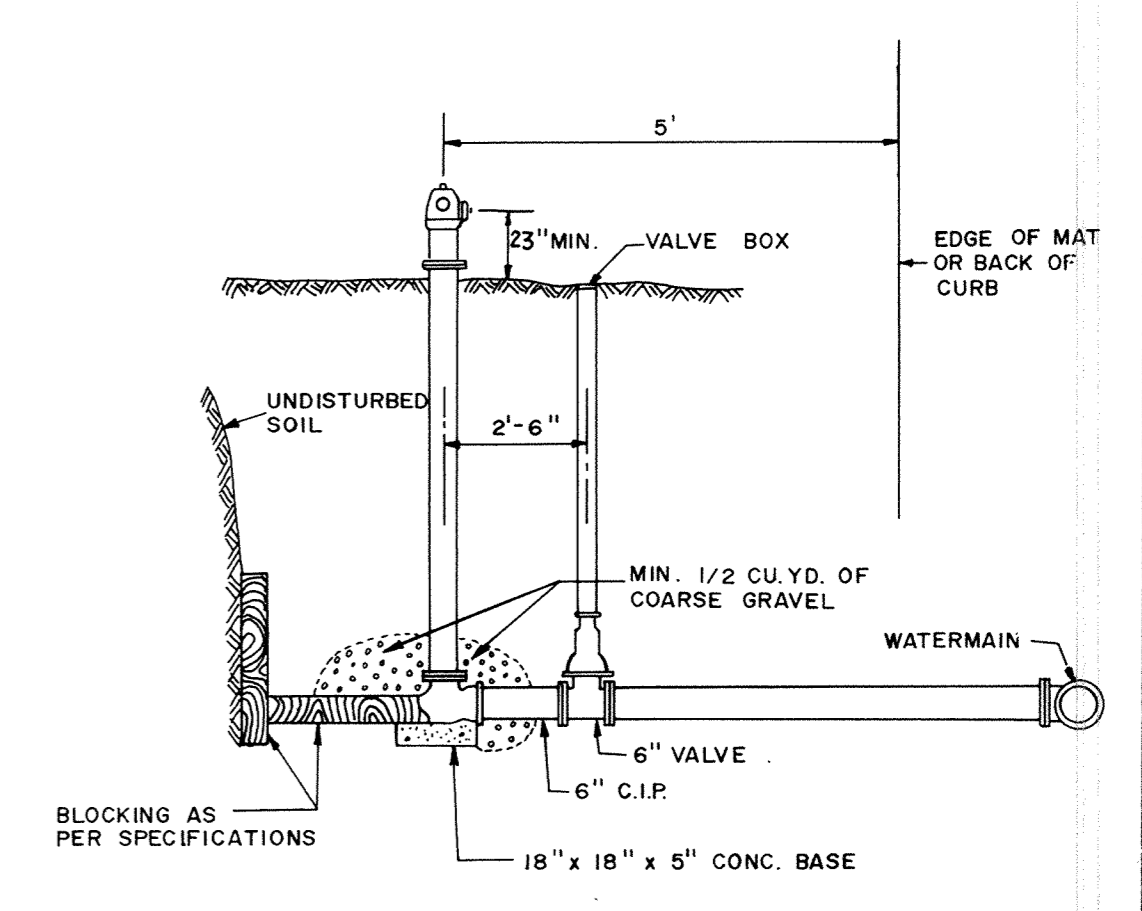

PACER HYDRANT DETAIL

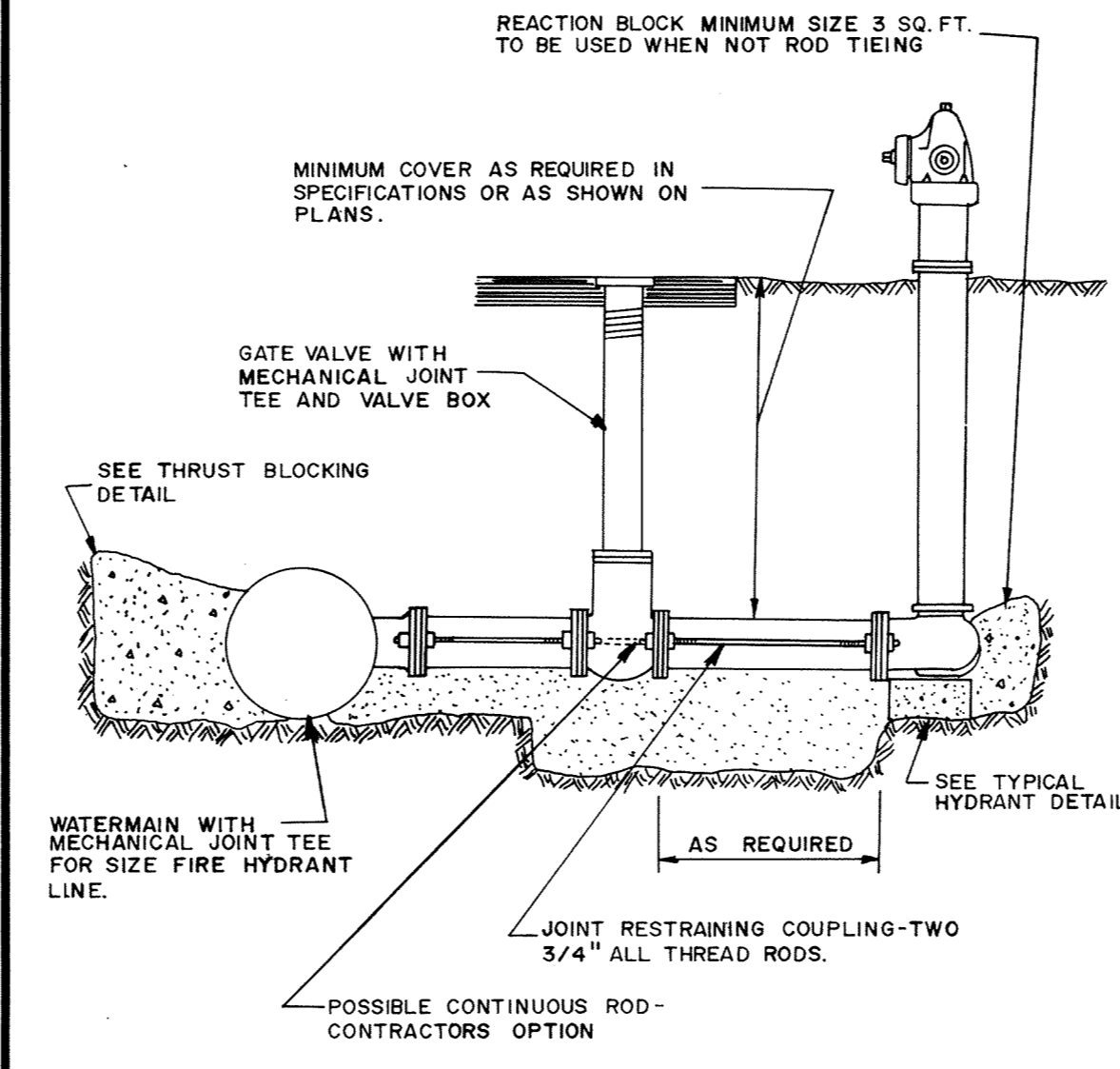
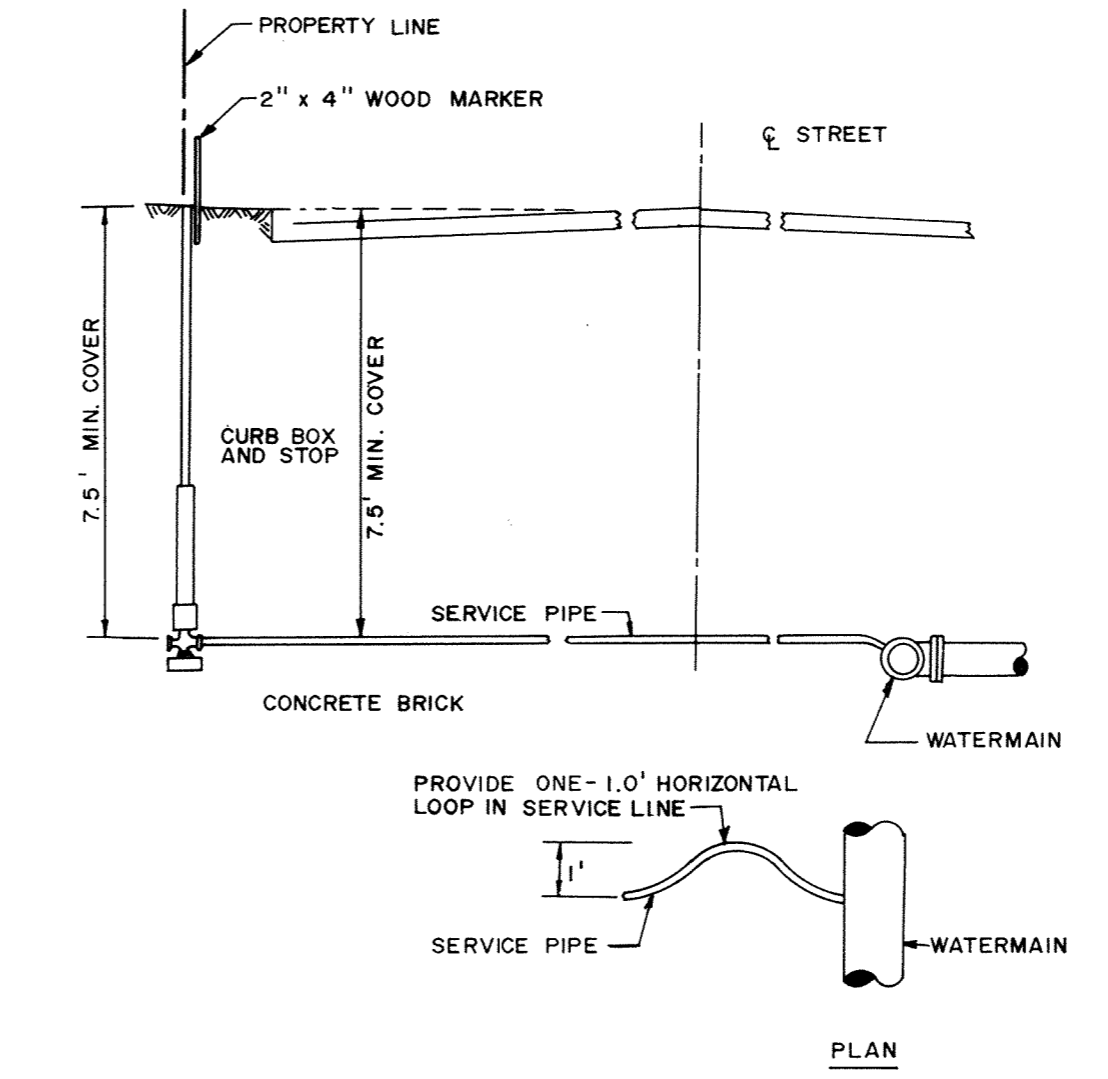

TYPICAL WATER LAYOUT

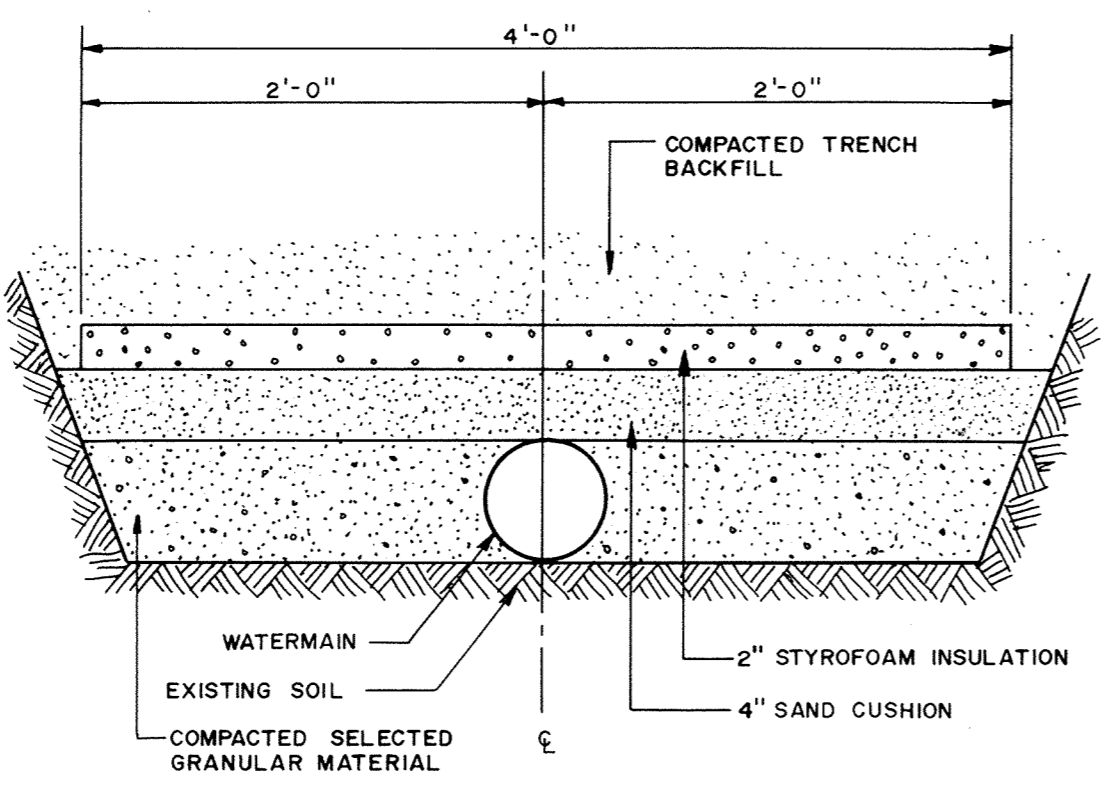

PIPE INSULATION DETAIL

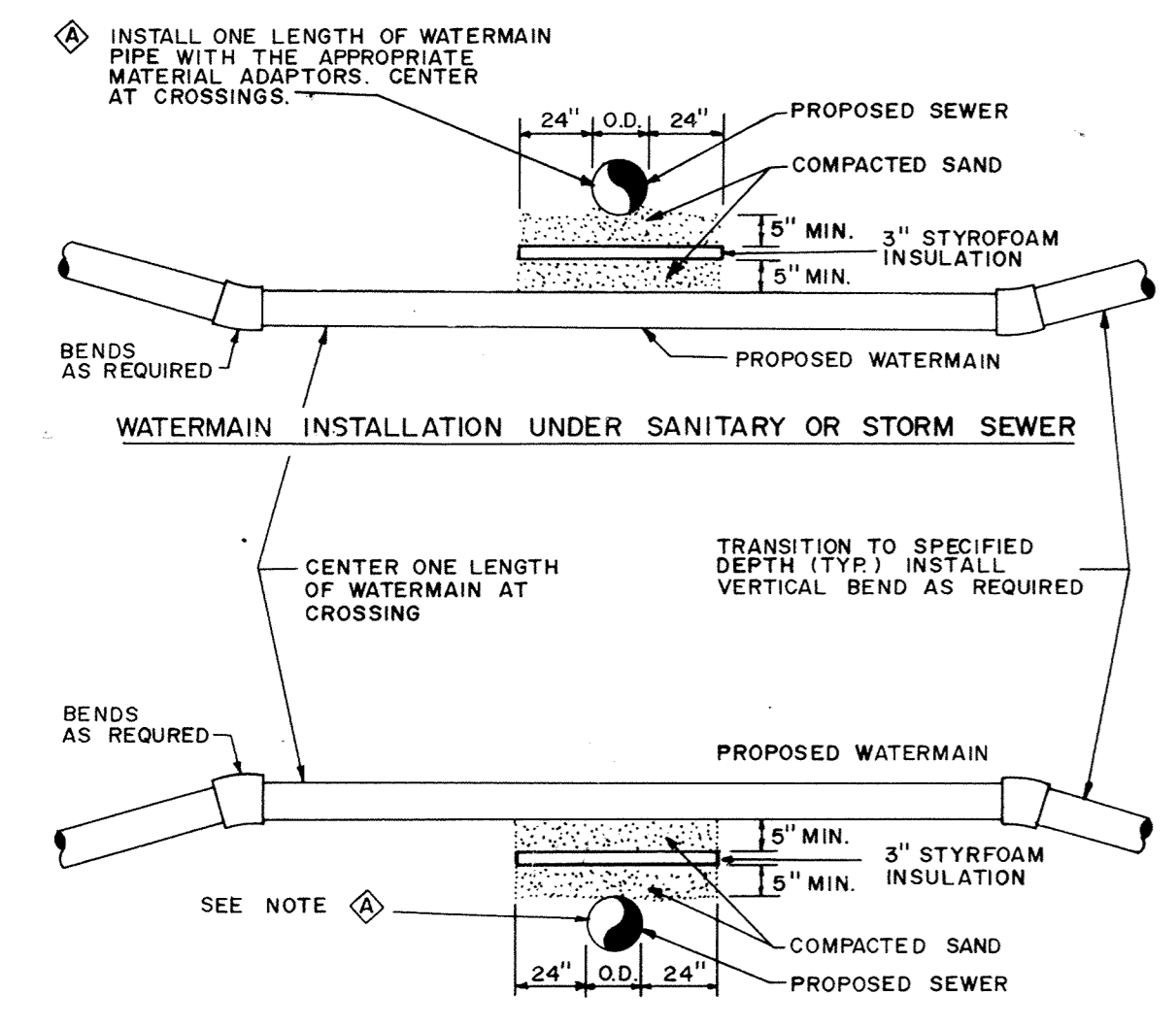

- NOTES:
1. WHEN WATERMAIN AND SANITARY SEWER CROSSINGS HAVE LESS THAN 18" VERTICAL SEPARATION, INSTALL CROSSING AS SHOWN.
  2. WHEN WATERMAIN COVER IS LESS THAN 7.5 FEET, INSTALL WATERMAIN UNDER SANITARY SEWER.

WATERMAIN CROSSING

TYPICAL HYDRANT DETAIL

SHERBURNE COUNTY  
S.A.P. 71-601-13  
WATERMAIN DETAILS

DATE FEB. 1991 SHEET 26 OF 28 SHEETS PROJECT NO. 231 001

**MSA** CONSULTING ENGINEERS  
Maier Stewart & Associates Inc.  
1959 SLOAN PLACE (612) 774-6021 ST. PAUL, MINNESOTA 55117

REVISIONS	DATE	DESCRIPTION	DESIGNED	CHECKED	DRAWN	GRAPHIC SCALE	VERT.